

12-VOLT THERMOPLASTIC BATTERY BACK-UP SUMP PUMP SYSTEM

blueangel™
PUMPS
The Professional's Line



- **47 GPM @ 5'**
- **Corrosion-Resistant Thermoplastic Construction**
- **Requires One 40 Amp or 75 Amp Deep Cycle Battery**
- **Battery Charger Keeps Battery Properly Charged**
- **Alarm System Lets Homeowner Know Standby System is Active**
- **Battery Case Included**
- **Compatible with Most Brands of Pedestal and Submersible Sump Pumps**

2
YEAR
Warranty

www.blueangelpumps.com

12-VOLT THERMOPLASTIC BATTERY BACK-UP SUMP PUMP SYSTEM



BSP25

- Vertical Float Switch
- 8', SJTW Power Cord
- Shipping Weight, 13 lbs
- 2 Year Warranty

PURCHASE A BLUE ANGEL PUMPS SEALED LEAD ACID BATTERY WITH THE SYSTEM, AND UPGRADE YOUR WARRANTY ON THE BATTERY TO 2 YEARS!!

BSB1275

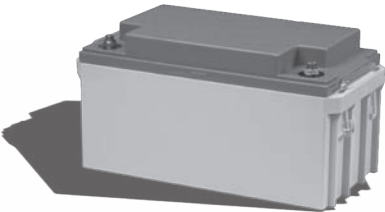

- 75 Amp Sealed Lead Acid Battery
- Up to 8 hours Continuous Run on Full Charge Battery
- Shipping Weight, 55 lbs
- 1 Year Warranty

BSB1240

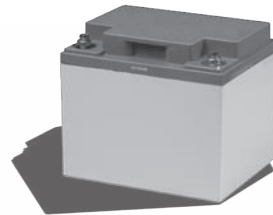

- 40 Amp Sealed Lead Acid Battery
- Up to 6 hours Continuous Run on Full Charge Battery
- Shipping Weight, 32 lbs
- 1 Year Warranty

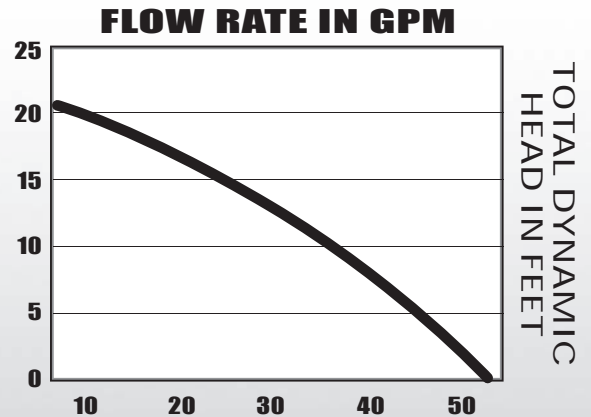
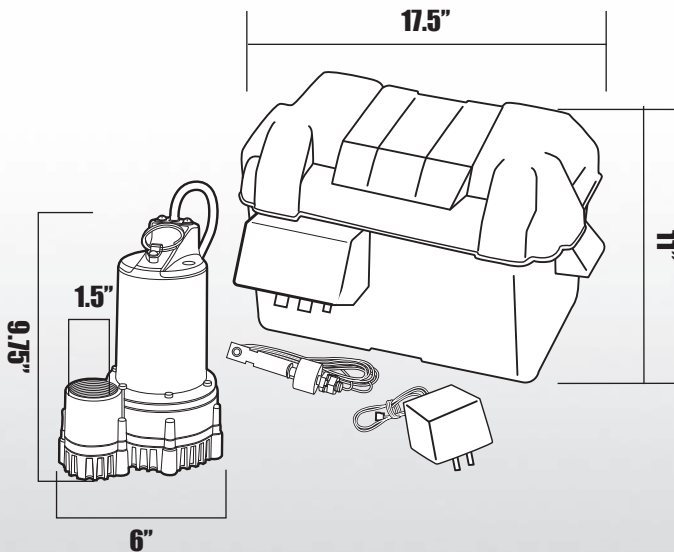

MOTOR SPECIFICATIONS

MOTOR	RPM	VOLTS	AMPS
Permanent Magnet	3500	12	16

PERFORMANCE

DISCHARGE HEAD	5'	10'	15'	20'
Gallons/Minute	47	38	25	2

FOR PUMP AND SYSTEM ACCESSORIES SEE ACCESSORIES SECTION
BLUE ANGEL™ PUMPS • 101 Production Drive • Harrison, OH 45030 • 1-888-636-6628

© 2008 Blue Angel Pumps All Rights Reserved