

# WATER POWERED BACK-UP SUMP PUMP SYSTEM

# blueangel<sup>™</sup> PUMPS

The Professional's Line

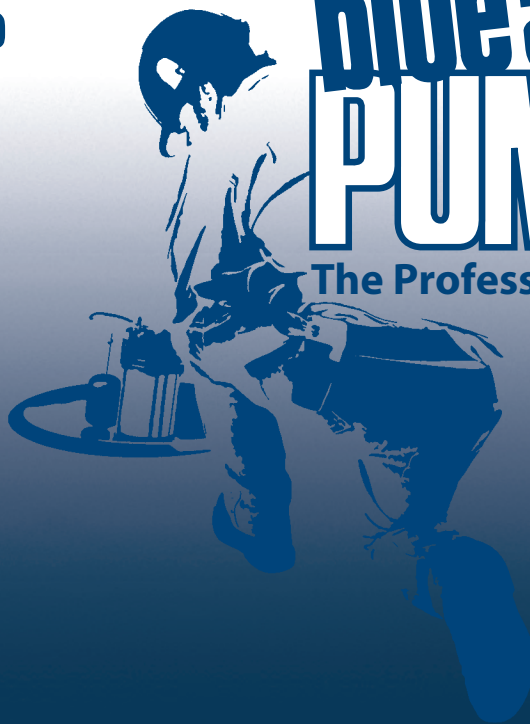

- **10 GPM @ 0'**
- **Protect Your Basement from Water.....With Water!!**
- **Backup Pump System is Powered by Municipal Water Pressure. No Electricity or Batteries Required!**
- **Corrosion Resistant Thermoplastic Construction for Long Life!**
- **Adjustable Float Switch for Automatic Operation**
- **Compatible with Any Pedestal or Submersible Sump Pump**

**2** YEAR  
Warranty

[www.blueangelpumps.com](http://www.blueangelpumps.com)

# WATER POWERED BACK-UP SUMP PUMP SYSTEM



## BEWP10

- Adjustable Vertical Float Switch
- Municipal Water Supply is a Minimum of 40 PSI - Maximum of 80 PSI
- 14" or Wider Sump Basins
- Comes Complete With Pump, Switch and Check Valve
- Shipping Weight, 4 lbs
- 2 Year Warranty

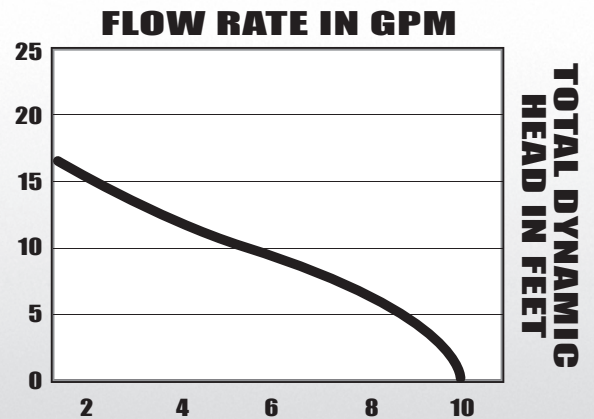
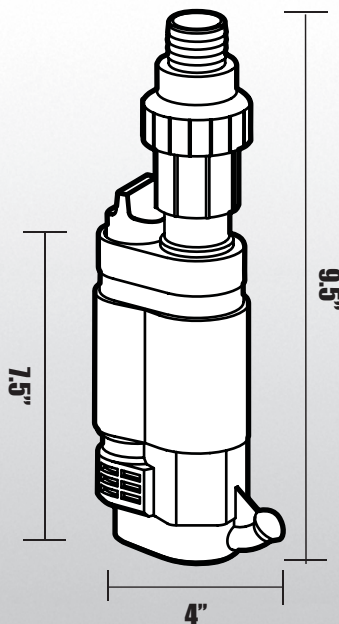

<b>PERFORMANCE</b>				
<b>DISCHARGE HEAD</b>	<b>0'</b>	<b>5'</b>	<b>10'</b>	<b>15'</b>
<b>Gallons/Minute</b>	10	9.7	5.2	2.6

FOR PUMP AND SYSTEM ACCESSORIES SEE ACCESSORIES SECTION  
 BLUE ANGEL™ PUMPS • 101 Production Drive • Harrison, OH 45030 • 1-888-636-6628

© 2008 Blue Angel Pumps All Rights Reserved