

1/2 HP HIGH HEAD "OIL DETECTIVE" SUMP SYSTEM



blueangel[™] PUMPS

The Professional's Line

• 50 GPM @ 20'

Designed to detect and alert of the presence of oil in various applications. The Switch is designed to adjust the on and off points to help prevent pumping oil into disposal systems. The alarm will alert of oil presence or high water conditions. The Oil Detective will monitor, watch and control the application – the detective is always on duty.

• Durable Cast Iron Design

• Heads Up to 60'

• System Includes:

- Pump Controller
- **Audible Alarms With Test and Silence Switch**
- Visual Display Lights
- Preset On and Off Points
- **20' Piggyback Switch Cord**
- **UL508 Approved Switch**

3 YEAR
Warranty

www.blueangelpumps.com

1/2 HP HIGH HEAD "OIL DETECTIVE" SUMP SYSTEM



ODS30

- IMPELLER
 - Cast Iron Casting
 - Recessed (Vortex) Design Reduces Bearing Load / Increased Bearing Life and Prevents Clogging
- SHAFT SEALS
 - Full Mechanical Seal (Carbon/Ceramic) For Extra Protection and Longer Life
- MOTOR
 - Permanent Split Capacitor Design for Assured Starting and Strong Torque
 - Internal Overload Protection
- 20', SJTW Power Cord
- Shipping Weight, 52lbs
- 3 Year Warranty

Typical Applications:

- Hydraulic Elevator Sumps
- Transformer Vaults
- Garages
- Anywhere Oil needs to be detected to comply with ASME 17.1 and other building codes.

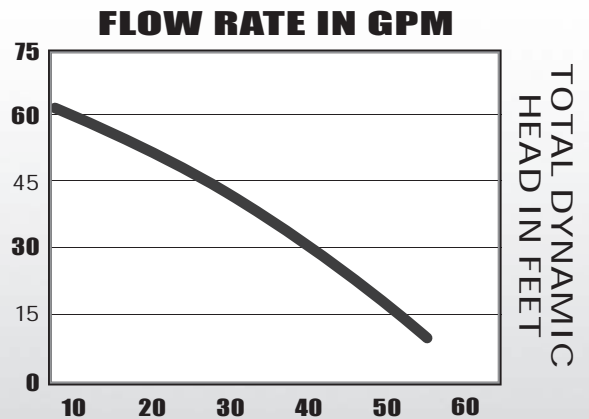
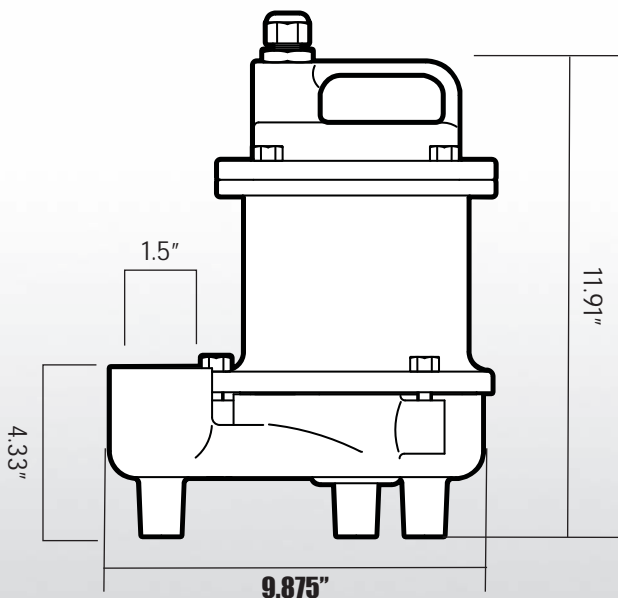

MOTOR SPECIFICATIONS

MOTOR	RPM	VOLTS	AMPS	Hz
Single Phase	3450	115/230	10.5/5.3	60

PERFORMANCE

DISCHARGE HEAD	10'	20'	30'	40'	50'	60'
Gallons/Minute	55	50	40	30	20	6

FOR PUMP AND SYSTEM ACCESSORIES SEE ACCESSORIES SECTION
 BLUE ANGEL™ PUMPS • 101 Production Drive • Harrison, OH 45030 • 1-888-636-6628

© 2008 Blue Angel Pumps All Rights Reserved