

1/2 HP "OIL DETECTIVE" SUMP SYSTEM



3 YEAR
WARRANTY



• 65 GPM @ 5'

Designed to detect and alert of the presence of oil in various applications. The Switch is designed to adjust the on and off points to help prevent pumping oil into disposal systems. The alarm will alert of oil presence or high water conditions. The Oil Detective will monitor, watch and control the application – the detective is always on duty.

• **Durable Cast Iron Volute, Stainless Steel Motor and Top Suction Design**

• **System Includes:**

- Pump Controller
- **Audible Alarms With Test and Silence Switch**
- Visual Display Lights
- Preset On and Off Points
- **20' Piggyback Switch Cord**
- UL508 Approved Switch

www.blueangelpumps.com

1/2 HP "OIL DETECTIVE" SUMP SYSTEM



ODS20

- Top Suction Design Prevents Debris From Jamming Pump
- IMPELLER
 - Poly-Carbonate Impeller
- MOTOR
 - Oil-Filled, Thermally Protected Motor Prevents Overheating
- 20', SJTW Power Cord
- Shipping Weight, 28lbs
- 3 Year Warranty

Typical Applications:

- Hydraulic Elevator Sumps
- Transformer Vaults
- Garages
- Anywhere Oil needs to be detected to comply with ASME 17.1 and other building codes.

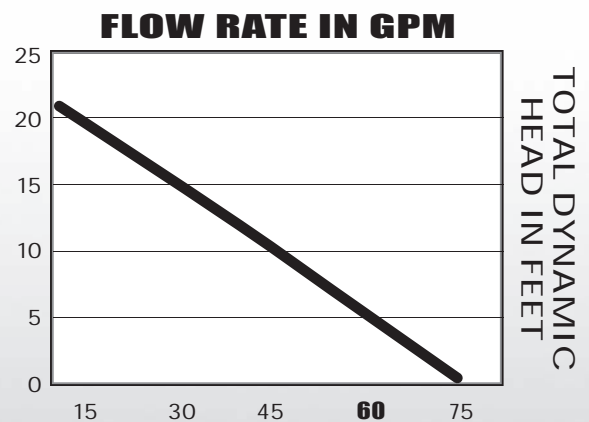
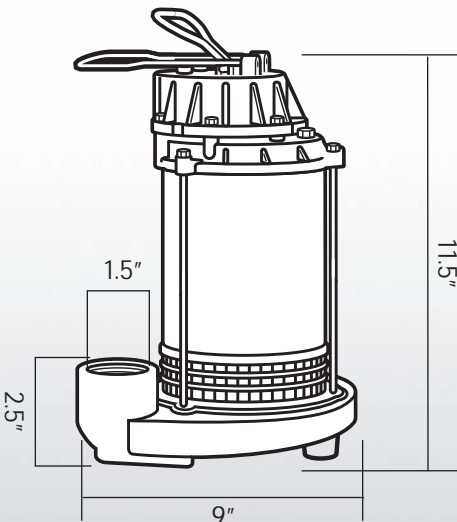

MOTOR SPECIFICATIONS

MOTOR	RPM	VOLTS	AMPS	Hz
Shaded Pole	1550	120	10	60

PERFORMANCE

DISCHARGE HEAD	5'	10'	15'	20'
Gallons/Minute	65	53	35	10

FOR PUMP AND SYSTEM ACCESSORIES SEE ACCESSORIES SECTION
BLUE ANGEL™ PUMPS • 101 Production Drive • Harrison, OH 45030 • 1-888-636-6628

© 2008 Blue Angel Pumps All Rights Reserved