

1/3 HP JOB-READY "SPECIALIST SERIES" CRAWLSPACE SUMP SYSTEM

blueangel[™] PUMPS

The Professional's Line



- 45 GPM @ 10'

- 1/3 HP Sump Pump

- 17" X 16" Polystuctural Foam Basin with 1/2" Holes Around Perimeter

- Polystuctural Foam Cover

- 1 1/2" Discharge



3 YEAR
Warranty

www.blueangelpumps.com

1/3 HP JOB-READY "SPECIALIST SERIES" CRAWLSPACE SUMP SYSTEM



BCS33CPS

- Vertical Float Switch
- 8', SJTW Power Cord
- ON Level at 7" / OFF Level at 3"
- Shipping Weight 30 lbs
- 3 Year Warranty

Reduces moisture in crawl space to help eliminate:

- Moisture damage to wood floor joists
- Mold and fungus development
- Odors from stagnant water
- Water accumulation due to clogged gutters or poor drainage
- Removal of water helps prevent moisture seeking rodents and insects

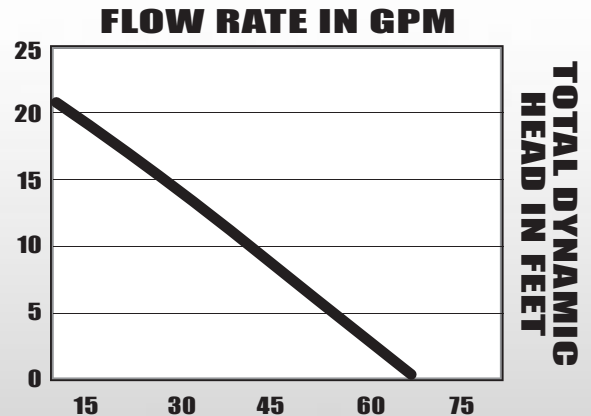
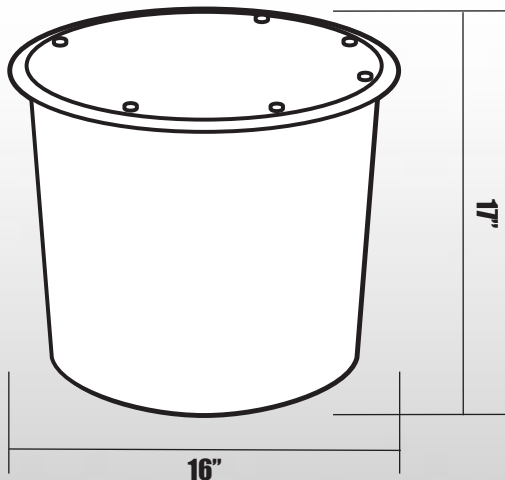

MOTOR SPECIFICATIONS

MOTOR	RPM	VOLTS	AMPS	Hz
Shaded Pole	1550	120	9.5	60

PERFORMANCE

DISCHARGE HEAD	5'	10'	15'	20'
Gallons/Minute	58	45	28	2

FOR PUMP AND SYSTEM ACCESSORIES SEE ACCESSORIES SECTION

BLUE ANGEL™ PUMPS • 101 Production Drive • Harrison, OH 45030 • 1-888-636-6628 • 1-877-289-2963

© 2007 Blue Angel Pumps All Rights Reserved