

1/2 HP  
PREASSEMBLED  
AND JOB-READY  
"SPECIALIST SERIES"  
OUTDOOR  
SEWAGE SYSTEM



**blueangel™**  
**PUMPS**  
The Professional's Line



- **113 GPM @ 5'**
- **1/2 HP Cast Iron Pump**
- **18" X 30" Polystructural Foam Basin and Lid**
- **Anti-Flotation Rim on Basin**
- **2" Side Discharge and Electrical Connection**
- **Full Flow 2" Check Valve Installed in Basin**
- **4" Snap-In Hub with Pipe Clamp**
- **Preassembled for Quick and Easy Installation**



Up To  
**5** YEAR  
Warranty

BCAPSE500DS Shown

[www.blueangelpumps.com](http://www.blueangelpumps.com)

# 1/2 HP PREASSEMBLED AND JOB-READY "SPECIALIST SERIES" OUTDOOR SEWAGE SYSTEM



## CSE50TODS

- Piggy-Back Tether Float Switch
- 10', SJTW Power Cord
- ON Level at 16" / OFF Level at 7.5"
- Shipping Weight 84 lbs.
- 2 Year Warranty



## BCAPSE500DS

- Piggy-Back Cap Switch
- Microprocessor Controlled - No Moving Parts to Wear Out No Adjustment Needed!
- 10', SJTW Power Cord
- Shipping Weight 84 lbs.
- **5 Year Warranty**

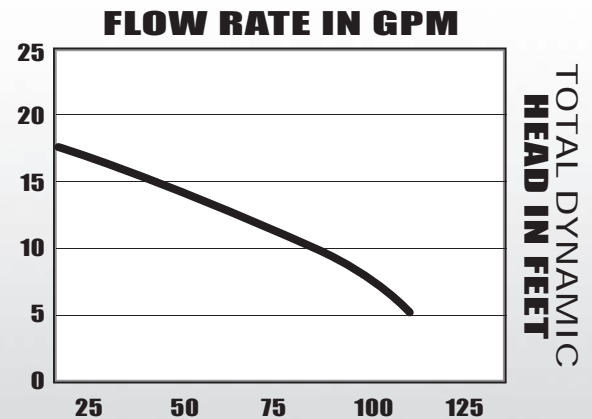
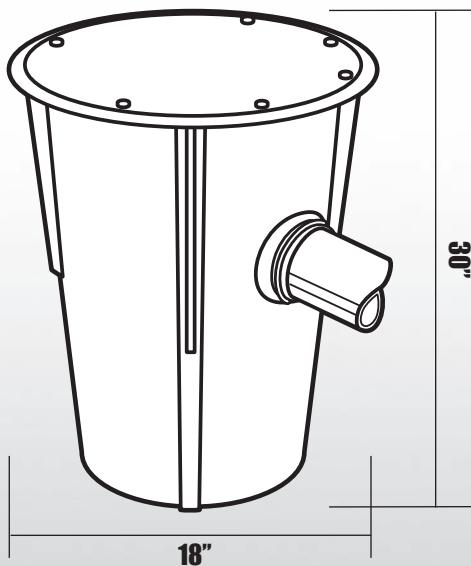

### MOTOR SPECIFICATIONS

MOTOR	RPM	VOLTS	AMPS	Hz
Split Phase	1725	120	8.7	60

### PERFORMANCE

DISCHARGE HEAD	5'	10'	15'	20'
Gallons/Minute	113	88	40	-

FOR PUMP AND SYSTEM ACCESSORIES SEE ACCESSORIES SECTION

BLUE ANGEL™ PUMPS • 101 Production Drive • Harrison, OH 45030 • 1-888-636-6628 • 1-877-289-2963

© 2008 Blue Angel Pumps All Rights Reserved