

1 HP CAST IRON SUBMERSIBLE COMMERCIAL SEWAGE PUMP



• **215 GPM @ 10'**

• **Cast Iron Motor Housing, Seal Plate, Volute and Impeller for Durability**

• **Stainless Steel Shaft and Fasteners**

• **Oil-Filled, Thermally Protected Motor Prevents Overheating**

• **3" NPT Discharge with 2" Adapter Capable of Handling 2" Solids**

• **Heavy-Duty Upper and Lower Ball Bearings for Long Life and Quiet Operation**

• **20 ft. Power Cord is Oil and Water Resistant with Neoprene Grommet for Superior Seal**

• **240 Volt Switches and Control Panel Sold Separately**

2
YEAR
Warranty

www.blueangelpumps.com

1 HP CAST IRON SUBMERSIBLE COMMERCIAL SEWAGE PUMP



BSE100

- Manual Operation
- 20', SJTW Power Cord
- 240 volt
- 18" or Wider Sewage Basins
- Shipping Weight, 104 lbs
- 2 Year Warranty

NOTE: Use With Single or Double Piggy-Back Float Switch or Control Panel

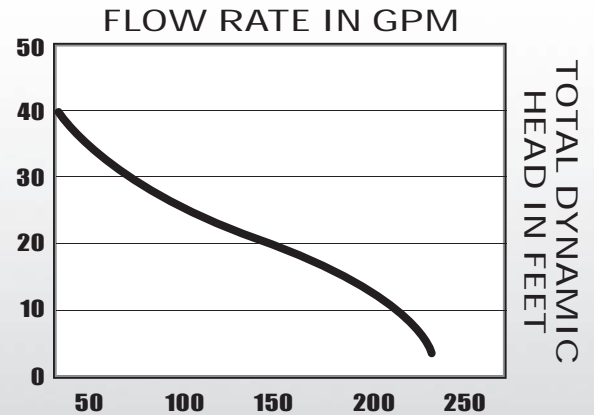
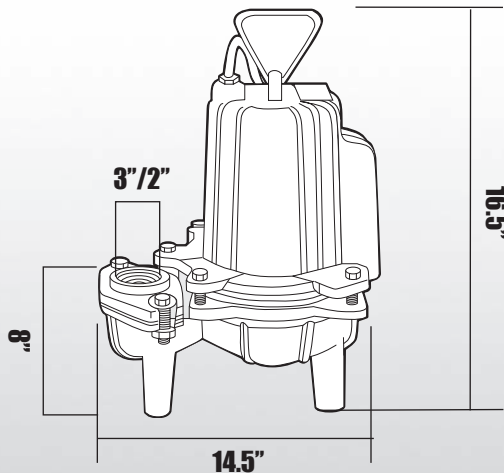

MOTOR SPECIFICATIONS

MOTOR	RPM	VOLTS	AMPS	Hz
PSC	1650	240	8.5	60

PERFORMANCE

DISCHARGE HEAD	10'	20'	30'	40'
Gallons/Minute	215	150	60	-

Preassembled Packages with Basin and Pump Available. See PACKAGED SYSTEMS Section.

FOR PUMP AND SYSTEM ACCESSORIES SEE ACCESSORIES SECTION

BLUE ANGEL™ PUMPS • 101 Production Drive • Harrison, OH 45030 • 1-888-636-6628

© 2008 Blue Angel Pumps All Rights Reserved

