

3/4 HP CAST IRON SUBMERSIBLE SEWAGE PUMP

blueangel[™] PUMPS

The Professional's Line

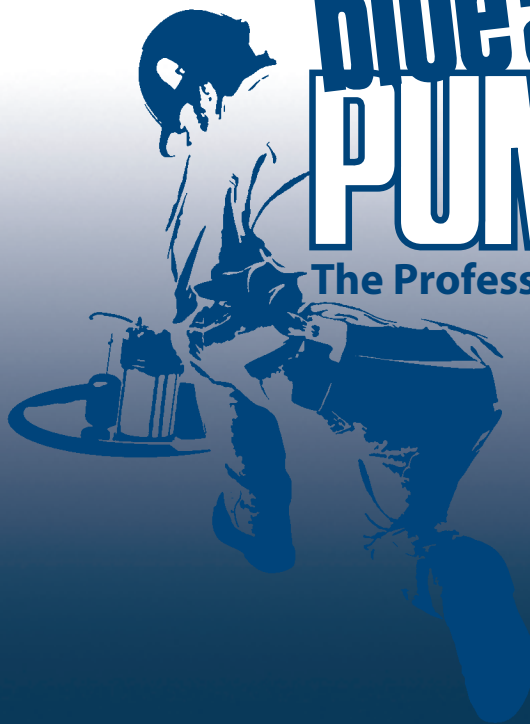

• **145 GPM @ 5'**

• **Cast Iron Motor and Pump Housing**

• **Oil-Filled, Thermally Protected Motor Prevents Overheating**

• **2" NPT Discharge Capable of Handling 2" Solids**

• **Lower Ball Bearing for Quiet Operation and Long Life**

• **Durable Components**

• **Designed for Residential and Light Commercial Sewage Applications**

• **Ideal for Basement or Below Grade Installations**

3 YEAR
Warranty

BEF75M Shown

www.blueangelpumps.com

3/4 HP CAST IRON SUBMERSIBLE SEWAGE PUMP



BEF75M

- Manual Operation
- 8', SJTW Power Cord
- 18" or Wider Sewage Basins
- Shipping Weight, 54 lbs
- 3 Year Warranty

NOTE: Use With Single or Double Piggy-Back Float Switch or Control Panel



BEF75T, BEF75T-2

- Piggyback Tether Float Switch
- 8', SJTW Power Cord (BEF75T)
- 20', SJTW Power Cord (BEF75T-2)
- 18" or Wider Sewage Basins
- ON level at 16" / Off level at 7.5"
- Shipping Weight, 54 lbs
- 3 Year Warranty

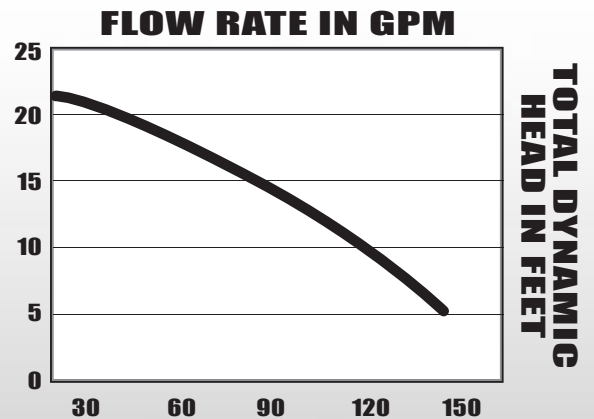
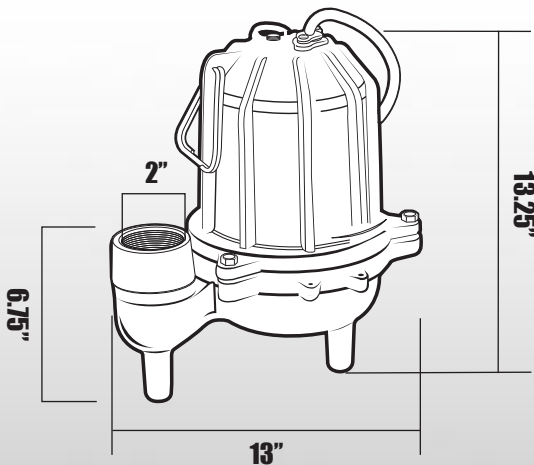

MOTOR SPECIFICATIONS

| MOTOR | RPM | VOLTS | AMPS | Hz |
|-------------|------|-------|------|----|
| Split Phase | 1725 | 120 | 11.8 | 60 |

PERFORMANCE

| DISCHARGE HEAD | 5' | 10' | 15' | 20' |
|----------------|-----|-----|-----|-----|
| Gallons/Minute | 145 | 127 | 88 | 45 |

Preassembled Packages with Basin and Pump Available. See PACKAGED SYSTEMS Section.

FOR PUMP AND SYSTEM ACCESSORIES SEE ACCESSORIES SECTION

BLUE ANGEL™ PUMPS • 101 Production Drive • Harrison, OH 45030 • 1-888-636-6628

© 2007 Blue Angel Pumps All Rights Reserved

