

1/2 HP  
"PUMP 'N' DOSE  
SERIES"  
EFFLUENT PUMP



**blueangel™**  
**PUMPS**  
The Professional's Line



• **50 GPM @ 20'**

- **3/4" Solids Handling**
- **Heavy Duty Mechanical Seal**
- **Durable Cast Iron Construction**
- **Upper and Lower Ball Bearings for Longer Life**

IMPELLER

**Cast Iron Casting for Rugged Operation and Dependable Service**

**Recessed (Vortex) Design Reduces Bearing Load / Increases Bearing Life and Prevents Clogging**

SHAFT SEALS

**Full Mechanical Seal (Carbon/Ceramic) for Extra Protection and Longer Life**

MOTOR

**Permanent Split Capacitor Design for Assured Starting and Strong Torque**

**Internal Overload Protection**

**2**  
YEAR  
Warranty

[www.blueangelpumps.com](http://www.blueangelpumps.com)

# 1/2 HP "PUMP 'N' DOSE SERIES" EFFLUENT PUMP

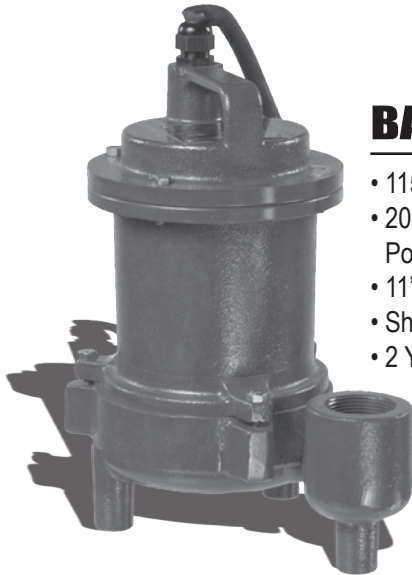

## BALE511A

- 115 Volt
- 20', SJTW OR SJTOW Power Cord
- 11" or Wider Basins
- Shipping Weight, 44 lbs
- 2 Year Warranty

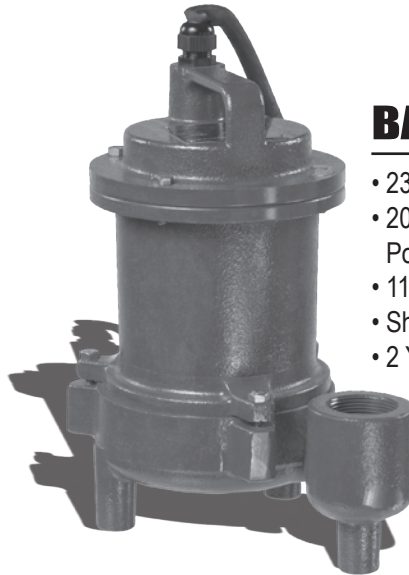

## BALE521A

- 230 Volt
- 20', SJTW OR SJTOW Power Cord
- 11" or Wider Basins
- Shipping Weight, 44 lbs
- 2 Year Warranty

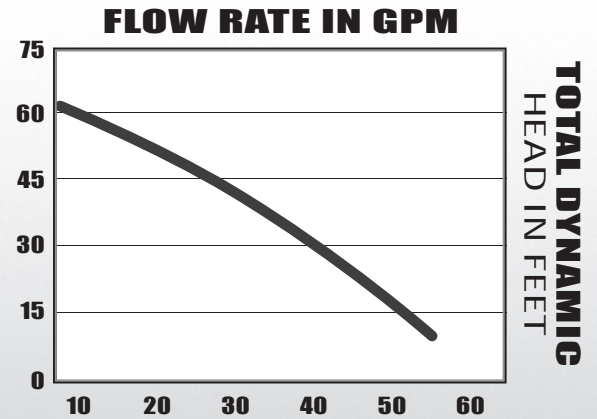
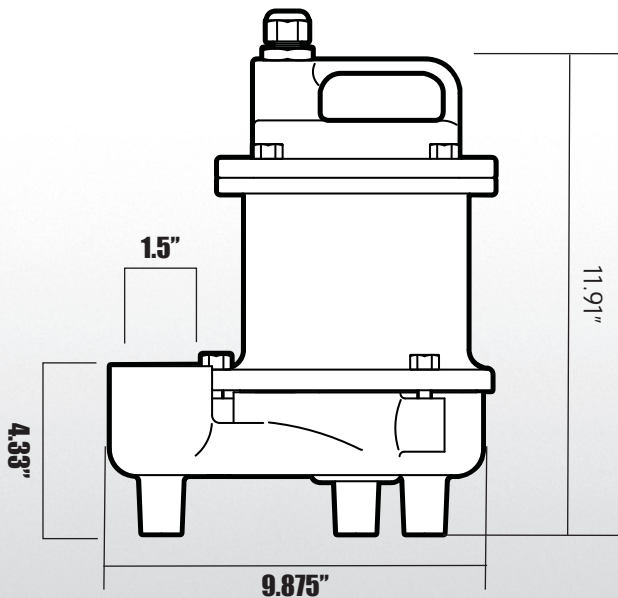

### MOTOR SPECIFICATIONS

MOTOR	RPM	VOLTS	AMPS	Hz
Single Phase	3450	115/230	10.5/5.3	60

### PERFORMANCE

DISCHARGE HEAD	10'	20'	30'	40'	50'	60'
Gallons/Minute	55	50	40	30	20	6

FOR PUMP AND SYSTEM ACCESSORIES SEE ACCESSORIES SECTION  
 BLUE ANGEL™ PUMPS • 101 Production Drive • Harrison, OH 45030 • 1-888-636-6628

© 2008 Blue Angel Pumps All Rights Reserved