

THERMOPLASTIC CONDENSATE PUMP

blueangel[™] PUMPS

The Professional's Line

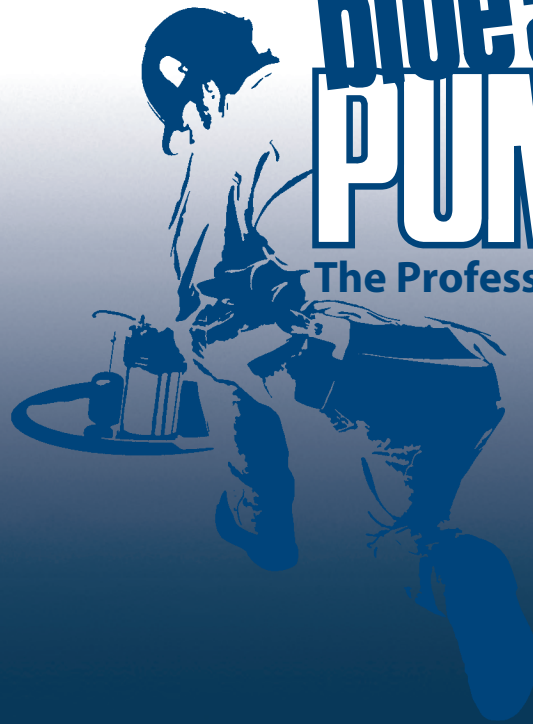

- **82 GPH @ 0'**
- **Durable Thermoplastic Construction with Built-In Mounting Brackets**
- **Built-In Automatic Float Switch with Overflow Safety Shut-Off**
- **2-Quart Reservoir**
- **3/8" Discharge with Integrated Check Valve**
- **6' Power Cord**
- **Automatically Removes Condensation from Air Conditioners, Furnaces and Dehumidifiers**



1
YEAR
Warranty

www.blueangelpumps.com

THERMOPLASTIC CONDENSATE PUMP

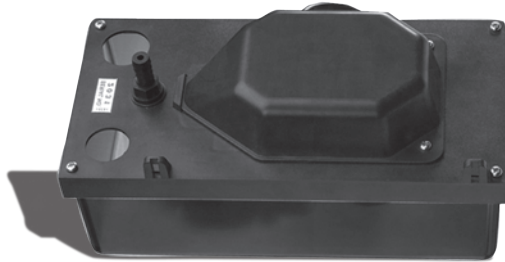

BCP20ULS

- Automatic Float Internal Float Switch
- 6', SJTW Power Cord
- Automatic
- Shipping Weight, 5 lbs
- 1 Year Warranty

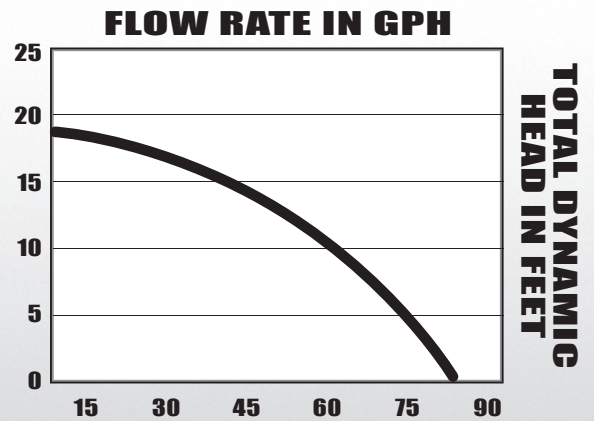
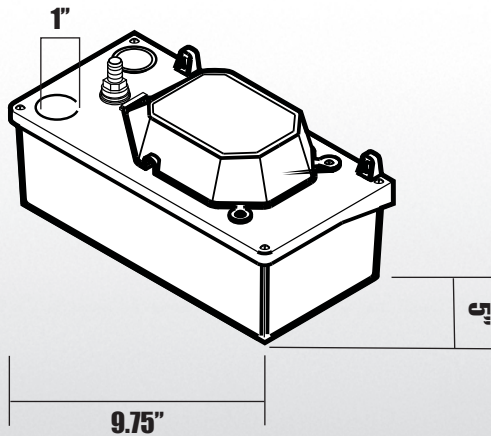

MOTOR SPECIFICATIONS

MOTOR	RPM	VOLTS	AMPS	HZ
Double Insulated	3000	120	1.45	60

PERFORMANCE

DISCHARGE HEAD	0'	4'	8'	12'
Gallons/Minute	82	75	66	52

FOR PUMP AND SYSTEM ACCESSORIES SEE ACCESSORIES SECTION
 BLUE ANGEL™ PUMPS • 101 Production Drive • Harrison, OH 45030 • 1-888-636-6628

© 2008 Blue Angel Pumps All Rights Reserved

