

Please read and save these instructions. Read carefully before attempting to assemble, install, operate or maintain the product described. Protect yourself and others by observing all safety information. Failure to comply with instructions could result in personal injury and/or property damage! Retain instructions for future reference.

Self-Priming Transfer Pumps

Table of Contents

Description1
 Unpacking1
 Safety Guidelines1
 General Safety Information1
 Installation2
 Operation2
 Maintenance3
 Troubleshooting Chart4
 Replacement Part Information 6-7
 Warranty8

Description

These self-priming transfer pumps are designed to easily transfer water from one point to another. Model BPC1, 12 Volt Transfer Pump is convenient when normal power is not readily available. Typical applications include removing water from pool covers, clogged drains, stock tanks, water basins, boats, cisterns, etc. Model BPC2, 120 Volt Transfer Pump is great for household usage. Typical applications include removing water from waterbeds, clogged sinks, basements, etc. Note: Do NOT use BPC2 in pool areas. The motors on both models BPC1 and BPC2 are non-submersible with overload protection.

Unpacking

Inspect this unit before it is used. Occasionally, products are damaged during shipment. If the pump or components are damaged, return the unit to the place of purchase for replacement. Failure to do so could result in serious injury or death.

READ & FOLLOW ALL INSTRUCTIONS

**SAVE THESE INSTRUCTIONS
DO NOT DISCARD**

Safety Guidelines

This manual contains information that is very important to know and understand. This information is provided for SAFETY and to PREVENT EQUIPMENT PROBLEMS. To help recognize this information, observe the following symbols.

⚠ DANGER Danger indicates an imminent hazardous situation which, if not avoided, WILL result in death or serious injury.

⚠ WARNING Warning indicates a potentially hazardous situation which, if not avoided, COULD result in death or serious injury.

⚠ CAUTION Caution indicates a potentially hazardous situation which, if not avoided, MAY result in minor or moderate injury.

NOTICE Notice indicates important information, that if not followed, may cause damage to equipment.

NOTE: Information that requires special attention.

General Safety Information

CALIFORNIA PROPOSITION 65

⚠ WARNING This product or its power cord may contain chemicals known to the State of California to cause cancer and birth defects or other reproductive harm. Wash hands after handling.

GENERAL SAFETY

⚠ DANGER Do not submerge motor or allow motor to be exposed to water. Personal injury and/or death could result. Keep pump and power cords away from liquids. Model BPC1 becomes very hot during operation.

⚠ DANGER Do not pump gasoline or other explosive liquids. Do not operate pump where flammable or explosive fumes or gases are present as a fire or explosion could result. Pump should only be used to pump clear water. Do not run pump dry.



1. Read all instructions before operation.
2. Protect electrical cord from sharp objects, hot surfaces, oil and chemicals. Avoid kinking the cord and replace damaged cords immediately.



⚠ CAUTION This pump has been evaluated for use with water only.

REMINDER: Keep your dated proof of purchase for warranty purposes! Attach it to this manual or file it for safekeeping.

Installation

Models BPC1 and BPC2 include a 6' suction hose, a water suction attachment, and a replacement parts kit which includes: impeller, gasket, shaft seal, and two motor brushes. Models BPC1 and BPC2 can be used without the water suction attachment.

⚠ DANGER

Always disconnect power source before attempting to install, service, or maintain the pump. Never handle a pump with wet hands or when standing on wet or damp surface or in water. Fatal electrical shock could occur.



1. A ground fault circuit interrupter (GFCI) is required for Model BPC2.

⚠ WARNING

Risk of electrical shock! This pump is supplied with a grounding conductor and grounding type attachment plug. A grounded receptacle in conformance with current NEC and local codes must be used (See Figure 1). Do not use model BPC2, 120 V Transfer Pump in swimming pool areas.



2. Model BPC1 operates on 12V DC only. Model BPC2 operates on 120V only. Voltage and current of power supply must match the requirements of the pump. Model BPC1 has color-coded battery clamps for 12V operation. Model BPC1 requires 14 amps at 12 VDC.
3. Never use an extension cord to power this unit.

⚠ WARNING

Risk of fatal electrical shock. Never cut off the round grounding prong. Cutting the cord or plug will void the warranty and make the pump inoperable.



4. Use a strainer when pumping from a creek, pond, or source where foreign objects may be sucked into the pump. The strainer should prevent solids from entering the inlet line.

5. A regular garden hose may be used as a discharge line.
6. Pump operation will be seriously hindered or prevented if the inlet hose is over 15 feet long or if the vertical pumping distance exceeds 10 feet.
7. At times, an overload due to overheating, low voltage, jammed impeller, etc. may shut the pump off. Unplug or turn off the pump and wait at least ten minutes. The pump will cool and automatically reset. (Model BPC2 only)
8. Motor should never be operated for more than 2 hours continuously. Critical heating can occur and might severely damage the pump and void warranty.

Operation

1. Add 1 tablespoon of vegetable oil to both inlet and outlet to prime. Attach included 6' suction hose to inlet of pump. Attach garden hose to outlet of pump. There must be a gasket in place to insure that these connections are airtight, otherwise the pump will not prime.
2. Connect water suction attachment to the open end of inlet hose and place below water surface. (Water suction attachment is optional for both BPC1 and BPC2 models.) The water suction attachment is designed to fit the male end of a garden hose. Place the water suction attachment as near as possible to the middle of the water that is to be pumped.
3. Examine the inlet and outlet hoses to insure there are no blockages, kinks or bends. The inlet hose should be no longer than 15 feet and the vertical pumping distance should not be any higher than 10 feet.

⚠ WARNING

Place switch in "OFF" position before connecting or disconnecting battery terminal clamps.

IMPORTANT BATTERY INFORMATION

Be certain that the area around the batteries is well ventilated. Before servicing the batteries, blow away gasses by waving a piece of cardboard near the batteries.

⚠ DANGER

Dangerous hydrogen gas can be released from batteries while charging. Sparks can ignite the gas in an enclosed space. Wear safety goggles when connecting batteries. Battery connections should be made in a well-ventilated area.

⚠ DANGER

Working in the vicinity of lead acid batteries can be dangerous. Before making connections or servicing the batteries, read and follow instructions in all applicable instruction manuals. To reduce the risk of battery explosion, follow the instructions in this manual and those published by the battery manufacturer, as well as those of any other equipment used in the surrounding area.

An assistant should be present or close enough to come to your aid in the event of an emergency. Have a reliable source of fresh water and soap nearby in case battery acid contacts clothing, skin or eyes.

Wear eye and clothing protection when working around lead acid batteries.

Avoid touching your eyes when working around lead acid batteries.

⚠ WARNING

If battery acid contacts your eye(s), flush with cold running water for 20 minutes and seek immediate medical attention. If acid contacts your skin or clothing, wash immediately with soap and water.

⚠ WARNING

Never smoke or allow a spark or flame in the vicinity of the battery.

⚠ WARNING

Avoid dropping metal tools on the battery posts because they may spark or short-circuit the system or battery, causing an explosion.

Operation (Continued)

- Connect pump to power source, with pump in a dry location. **Model BPC1:** Motor must be connected to a fully charged automotive tractor or marine type battery to operate. Connect the red clamp to the positive (+) type battery terminal. Connect the black clamp to the negative (-) type battery terminal. See 12V wiring diagram below (Figure 2). **Model BPC2:** Plug into a 3-prong ground-type AC receptacle.

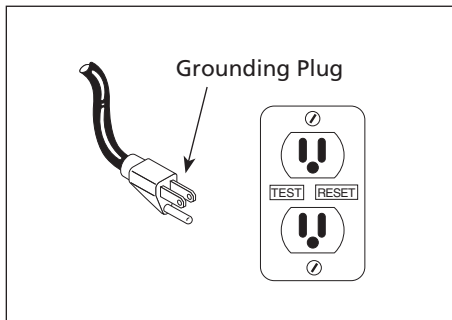

Figure 1

Maintenance

⚠ DANGER Always disconnect power source before attempting to install, service, or maintain the pump.

IMPELLER REPLACEMENT

These parts are designed to handle most clear, nonflammable liquids with slight amounts of abrasives. When impeller vanes become worn from use, or damaged due to pumping abrasive liquids or trash, pump performance will be reduced or prevented altogether.

- Remove the four cover plate screws holding motor housing and pump housing together. Cover plate is now free and can be removed.
- Inspect gasket and impeller for wear and damage. If there is any evidence of wear or damage, replace the part(s).
- Lubricate new impeller with white grease or lightweight oil and reinstall by aligning flat on impeller hub with flat on motor shaft.

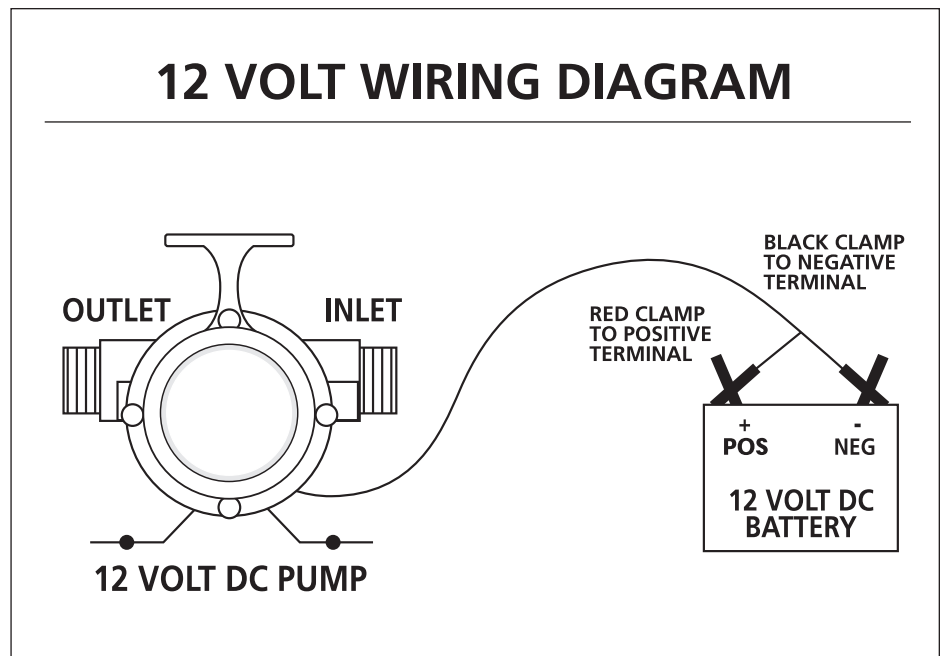

Figure 2

- Reassemble gasket, cover plate, and cover plate screws.

SHAFT SEAL REPLACEMENT

Motor shafts are sealed with factory pre-lubricated lip-type seals which are good for the life of the pump. If the seal leaks, it is usually because the pump has handled abrasive liquids. If the motor shaft is scored (deep grooves), the complete pump must be replaced.

- Remove and inspect impeller parts as specified in the impeller replacement instructions. Replace worn parts.
- Remove two pump body mounting screws and slide pump body from motor. Pry out seal retaining ring and push worn shaft seal from inside of pump body.
- Lubricate new seal with lightweight oil, push it into pump body with lip facing away from motor, and push in seal retaining ring.
- Reassemble pump body onto motor with mounting screws. Follow steps 3 and 4 in Impeller Replacement.

MOTOR BRUSH REPLACEMENT

NOTICE Brushes for this pump should be inspected after 75 hours of operation and replace if worn. They must be replaced every 150 hour of operation. Service one brush at a time.

- Disconnect pump from power supply.
- Remove brush caps with screwdriver.
- Remove old brush assembly.
- Insert new brush assembly.
- Replace brush caps.

Troubleshooting Chart

| Symptom | Possible Cause(s) | Corrective Action |
|---|---|---|
| Pump will not start or run | <ol style="list-style-type: none"> 1. Blown fuse 2. Low line voltage 3. Worn brushes 4. Impeller blocked 5. Motor has overheated (Model BPC2 only) | <ol style="list-style-type: none"> 1. If blown, replace with proper sized fuse or reset breaker 2. Voltage of power supply must match the voltage of the pump 3. Replace brushes 4. Remove blockage 5. Disconnect from power supply and allow to cool (Minimum 10 minutes) |
| Pump will not prime or retain prime after operating | <ol style="list-style-type: none"> 1. Air leak in suction line 2. Impeller blocked 3. Worn seal 4. Suction lift too high 5. Hose kinked or looped 6. Fittings not tight 7. Suction hose out of water 8. Clogged inlet | <ol style="list-style-type: none"> 1. Repair suction line by tightening inlet connection or replace 2. Remove blockage 3. Replace seal 4. Lower pump 5. Straighten hose 6. Tighten fittings 7. Submerge suction hose end 8. Clean inlet |
| Flow rate is too low | <ol style="list-style-type: none"> 1. Inlet hose plugged or kinked 2. Low line voltage | <ol style="list-style-type: none"> 1. Clean or replace 2. Voltage of power supply must match the voltage of the pump |
| Shaft seal leaks | <ol style="list-style-type: none"> 1. Worn seal 2. Shaft grooved 3. Pump head loose on motor | <ol style="list-style-type: none"> 1. Replace seal 2. Replace pump 3. Insure proper assembly and no obstruction, tighten bolts |

For Replacement Parts or Technical Assistance, Call 1-888-636-6628

Please provide following information:

- Model number
- Serial number (if any)
- Part description and number as shown in parts list

Address any correspondence to:

Blue Angel Pumps
101 Production Drive
Harrison, OH 45030 U.S.A.

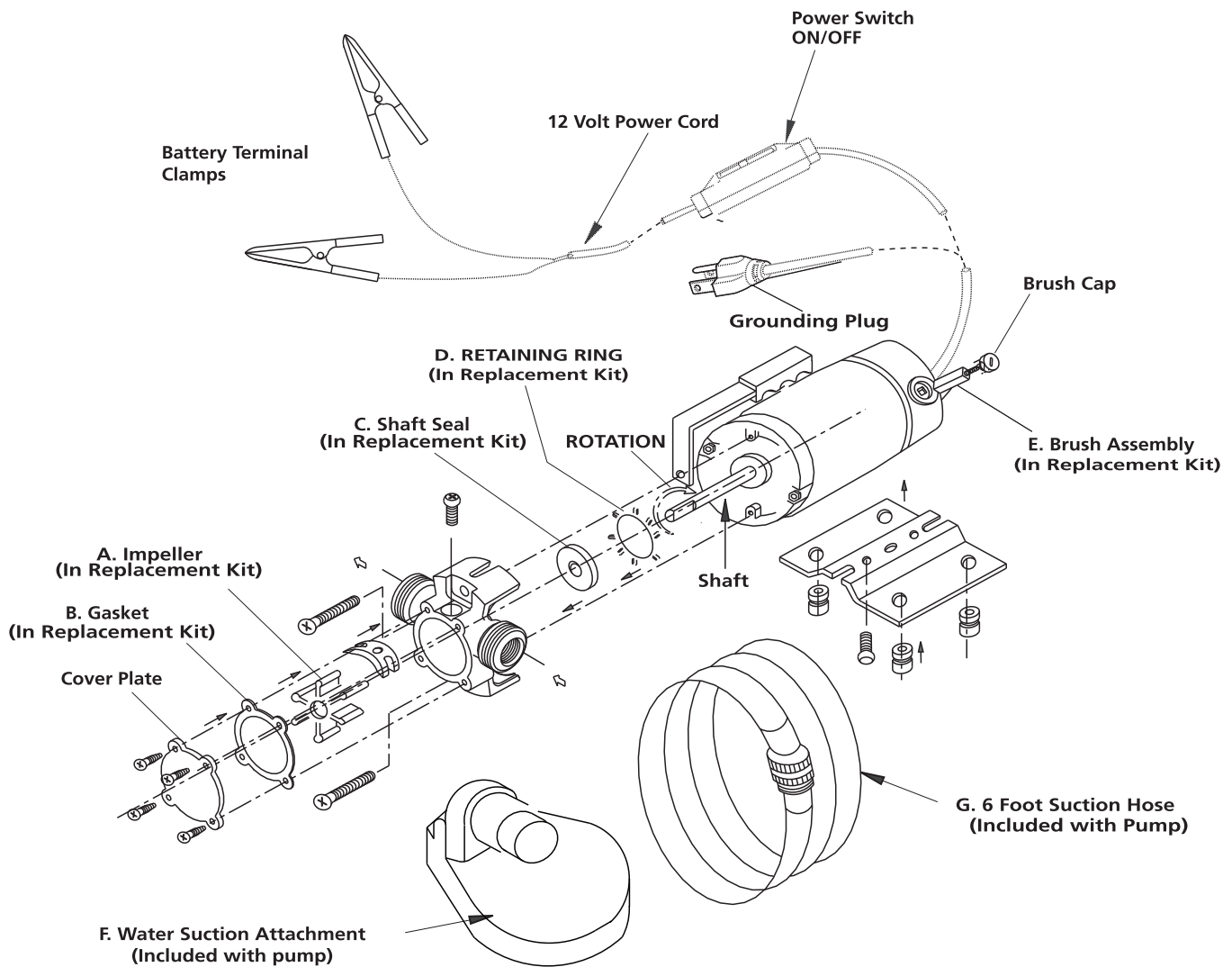

Figure X – Replacement Parts Illustration for Self-Priming Transfer Pumps

Replacement Parts List for Self-Priming Transfer Pumps

| Reference Number | Description | Part Number for Models: | | Quantity |
|------------------|-----------------------------|-------------------------|------------|----------|
| | | BPC1 | BPC2 | |
| 1 | Brush and Impeller Kit | 66062-WYN1 | 66058-WYN1 | |
| | A. Impeller | | | 1 |
| | B. Gasket | | | 2 |
| | C. Shaft Seal | | | 1 |
| | D. Retaining Ring | | | 1 |
| | E. Brushes | | | 2 |
| 2 | Water Suction Attachment | 66064-WYN1 | 66064-WYN1 | |
| | F. Water Suction Attachment | | | 1 |
| | G. 6 ft. Suction Hose | | | 1 |

NOTE: Replacement parts are available in kit form only

Limited Warranty

For one year from the date of purchase, Blue Angel Pumps will repair or replace, at its option, for the original purchaser any part or parts of its Sump Pumps or Water Pumps ("Product") found upon examination by Blue Angel to be defective in materials or workmanship. Please call Blue Angel (888-636-6628) for instructions or see your dealer. Be prepared to provide the model number when exercising this warranty. All transportation charges on Products or parts submitted for repair or replacement must be paid by purchaser.

This Limited Warranty does not cover Products which have been damaged as a result of accident, abuse, misuse, neglect, improper installation, improper maintenance, or failure to operate in accordance with Blue Angel's written instructions.

THERE IS NO OTHER EXPRESS WARRANTY. IMPLIED WARRANTIES, INCLUDING THOSE OF MERCHANTABILITY AND FITNESS FOR A PARTICULAR PURPOSE, ARE LIMITED TO ONE YEAR FROM THE DATE OF PURCHASE. THIS IS THE EXCLUSIVE REMEDY AND ANY LIABILITY FOR ANY AND ALL INDIRECT OR CONSEQUENTIAL DAMAGES OR EXPENSES WHATSOEVER IS EXCLUDED.

Some states do not allow limitations on how long an implied warranty lasts, or do not allow the exclusions or limitations of incidental or consequential damages, so the above limitations might not apply to you. This limited warranty gives you specific legal rights, and you may also have other legal rights which vary from state to state.

In no event, whether as a result of breach of contract warranty, tort (including negligence) or otherwise, shall Blue Angel or its suppliers be liable for any special, consequential, incidental or penal damages including, but not limited to loss of profit or revenues, loss of use of the products or any associated equipment, damage to associated equipment, cost of capital, cost of substitute products, facilities, services or replacement power, downtime costs, or claims of buyer's customers for such damages.

You **MUST** retain your purchase receipt along with this form. In the event you need to exercise a warranty claim, you **MUST** send a **copy** of the purchase receipt along with the material or correspondence. Please call Blue Angel (888-636-6628) for return authorization and instructions.

DO NOT MAIL THIS FORM TO BLUE ANGEL. Use this form only to maintain your records.

MODEL NO. _____ SERIAL NO. _____ INSTALLATION DATE _____

ATTACH YOUR RECEIPT HERE