

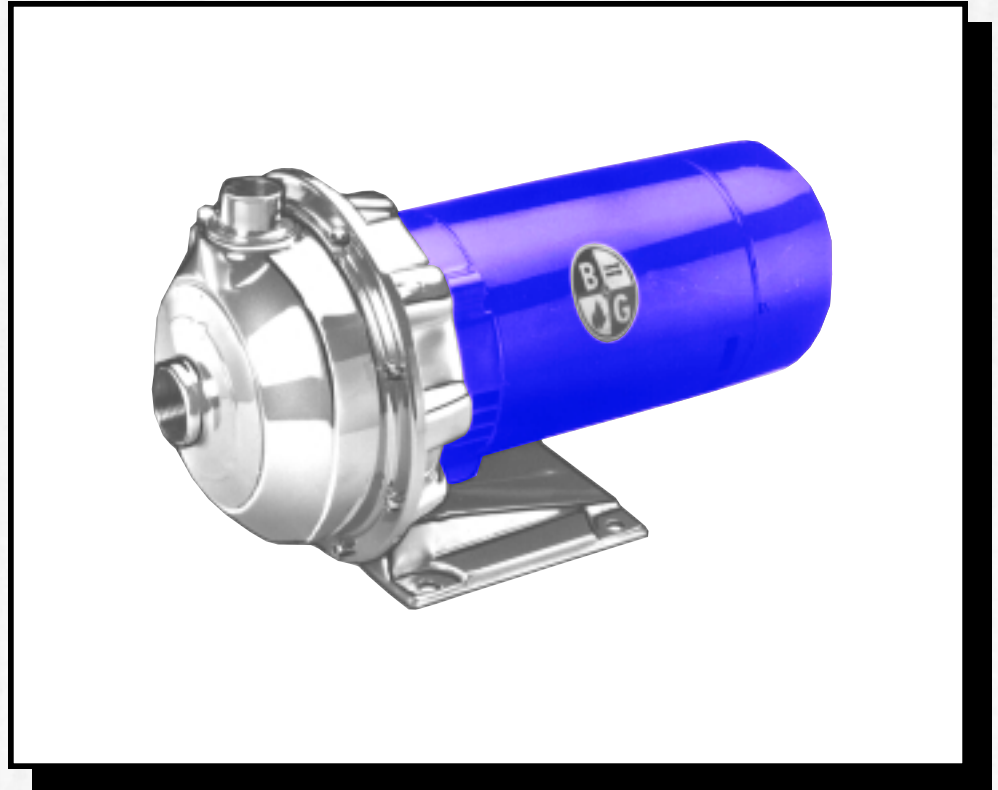

Bell & Gossett



Series 3530 Quantek Pumps

The Standard in Close Coupled General Service Pumps

Capacities to 170 GPM
Heads to 150 ft.

Applications:

- Cooling Tower
- Circulation
- OEM Packages
- Pressure Boosting
- Condensate
- Domestic Water

Bell & Gossett



ITT Industries
Engineered for life

SERIES 3530

SELECTION CHART

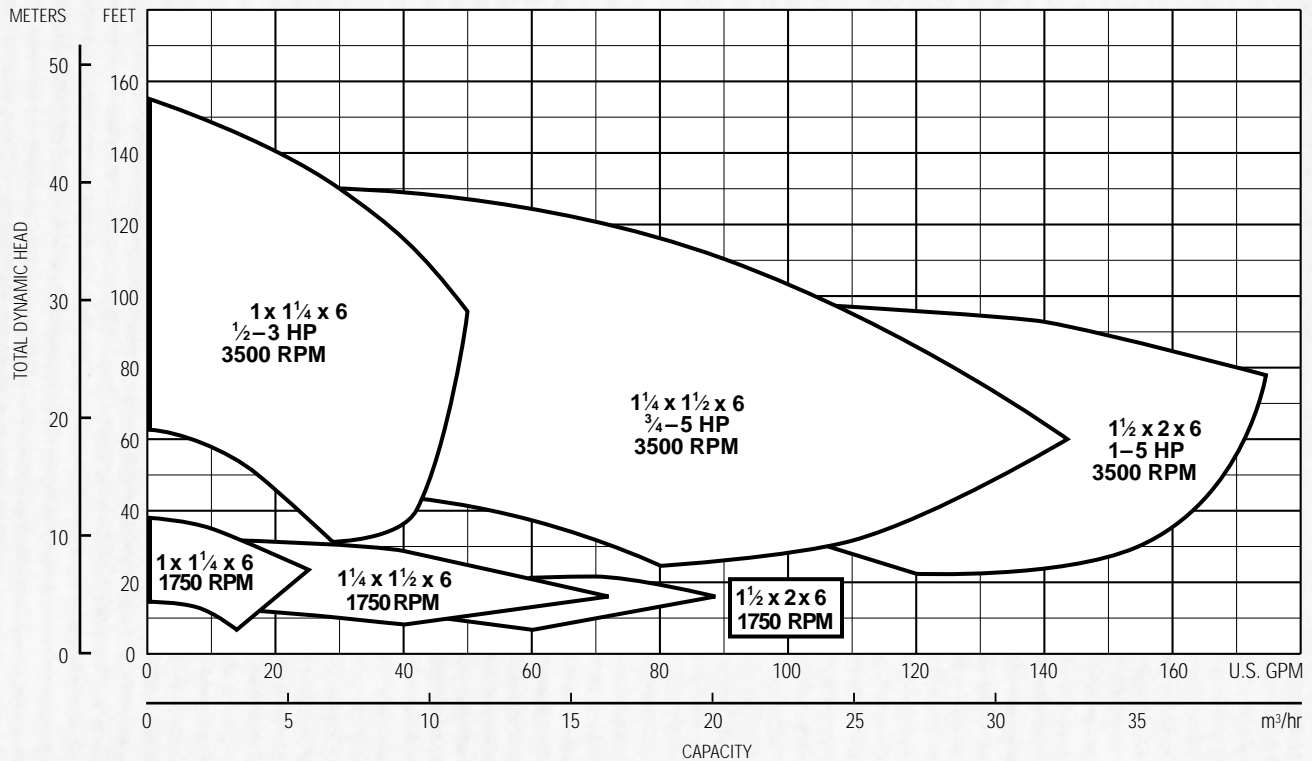

FEATURES

- Superior Materials of Construction:** Complete AISI 316L stainless steel liquid handling components and mounting bracket for corrosion resistance, quality appearance, and improved strength and ductility.
- High Efficiency Impeller:** Enclosed impeller with unique floating seal ring design maintains maximum efficiencies over the life of the pump without adjustment.
- Casing and Adapter Features:** Stainless steel construction with NPT threaded, centerline connections, easily accessible vent, prime and drain connections with stainless steel plugs.
- Mechanical Seal:** Standard John Crane Type 21 with Carbon versus Silicon-Carbide faces, Viton elastomers, and 316 stainless metal parts. Optional high temperature seal available.
- Multiple Discharge Positions:** Standard pump supplied with top vertical discharge. Casing can be field rotated every 45° for flexible installations.

SPECIFICATIONS

Capacities to:
75 GPM (283L/min) at 1750 RPM
170 GPM (643L/min) at 3500 RPM
Not recommended for operation beyond printed curve.

Heads to:
39 feet (11m) at 1750 RPM
150 feet (50m) at 3500 RPM

Working pressures to:
125 PSIG (9 bars)

Maximum temperatures to:
225°F (107°C) with standard seal or 250°F (121°C) with optional high temperature seal.

Direction of rotation:
Clockwise when viewed from motor end.

Motor:
NEMA 56J frame. 1750 RPM, 1/2 HP. 3500 RPM, 1/2 through 5 HP. Open drip-proof and totally enclosed fan-cooled enclosures. Stainless steel shaft with ball bearings.

Single phase: Voltage 115/230 ODP and TEFC. (3 HP model - 230V only) Built-in overload with auto-reset provided.

Three phase: Voltage 208-230/460 ODP and TEFC.

All standard 3500 RPM ODP and TEFC motors supplied by B&G have minimum of 1.15 service factor. Standard catalog units may utilize available service factor.

Note: For three phase motors, overload protection must be provided in starter unit. Starter and heaters must be ordered separately.

MATERIALS OF CONSTRUCTION

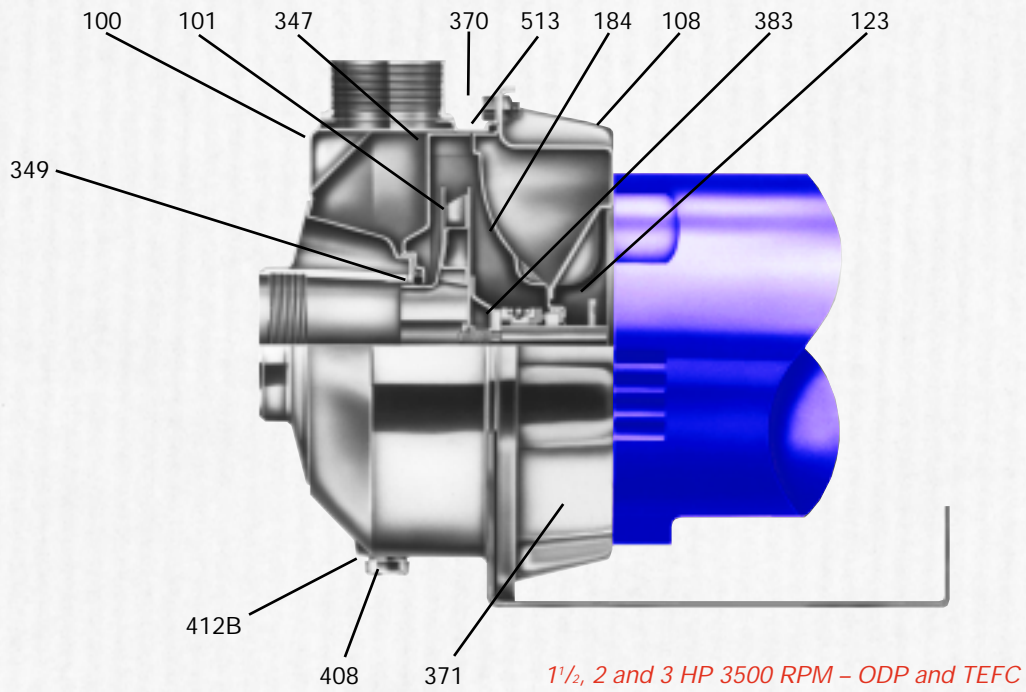

Item No.	Description	Materials
100	Casing	
101	Impeller	AISI 316L SS
108	Motor adapter	
123	Deflector	BUNA-N
184	Seal housing	AISI 316L SS
347	Guidevane	
349	Seal ring, guidevane	Viton
370	Socket head screws, casing	AISI 410 SS
371	Bolts, motor	Plated steel
383	Mechanical seal	Viton/Carbon-Silicon Carbide
408	Drain and vent plug, casing	AISI 316L SS
412B	O-ring, drain and vent plug	Viton
513	O-ring, casing	Viton
Motor	NEMA standard, 56J flange	316 SS Shaft

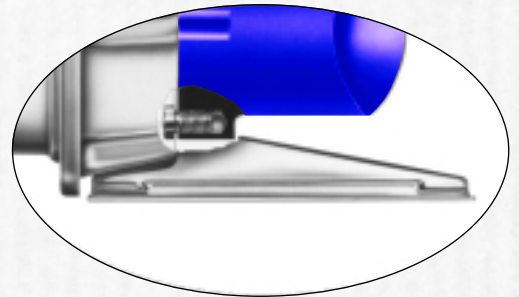

1/2, 3/4 and 1 HP 3500 RPM - ODP and TEFC

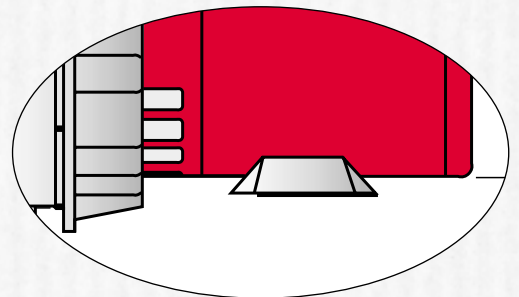

Footed motor for 1750 RPM and 5 HP 3500 RPM - ODP and TEFC

SERIES 3530 PUMP PERFORMANCE CURVES

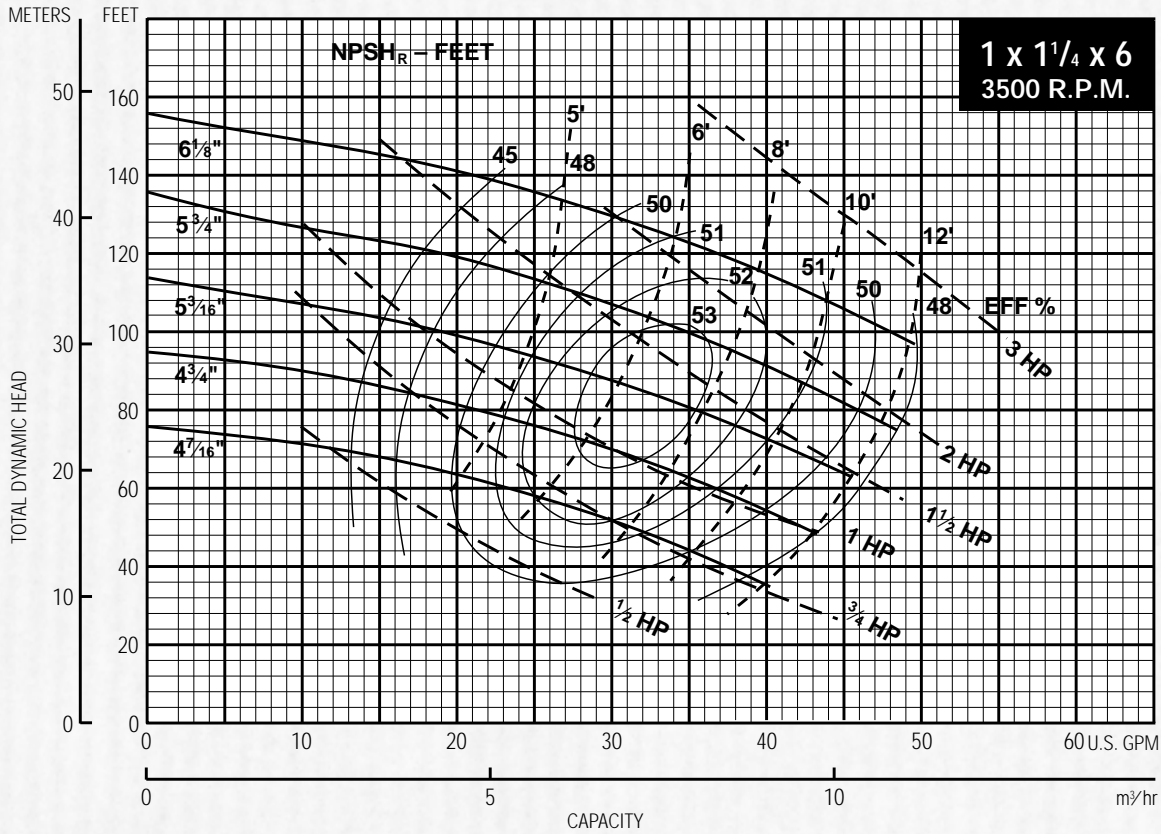

1 x 1 1/4 x 6 3500 RPM	
IMPELLER DIAMETER	HP
4 7/16	1/2 3/4
4 3/4	3/4 1
5 3/16	1 1 1/2
5 3/4	1 1/2 2
6 1/8	2 3

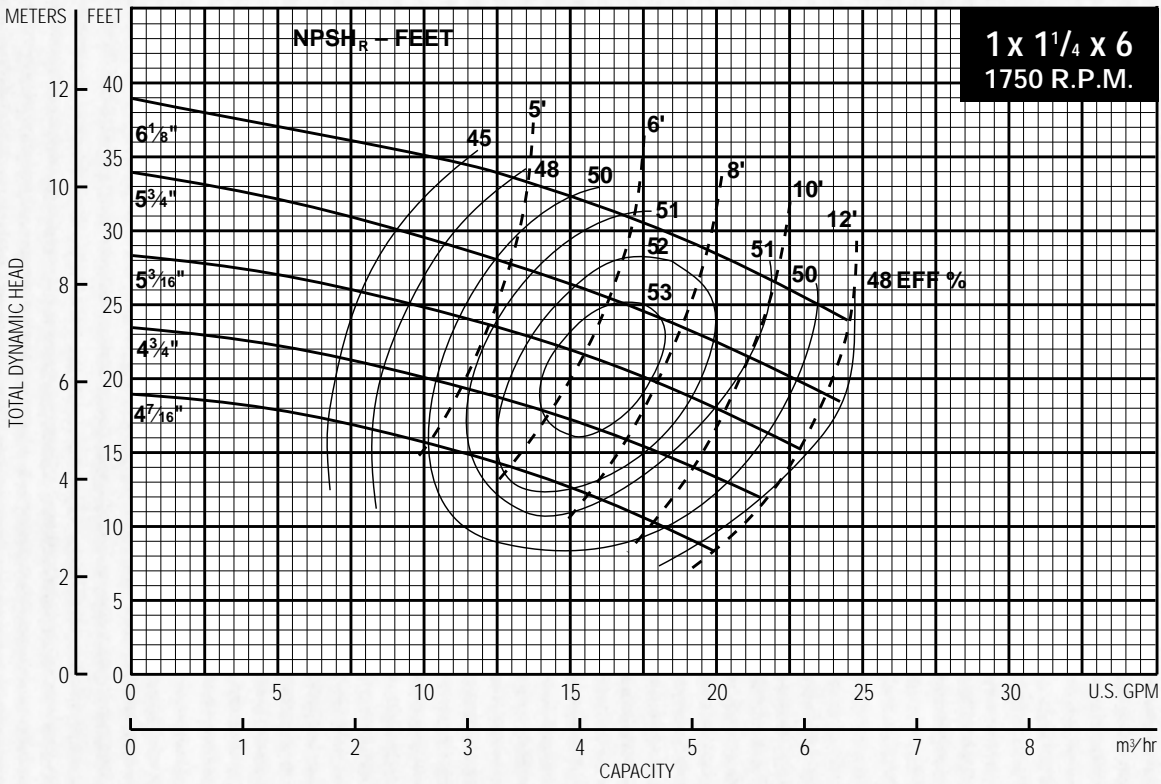

1 x 1 1/4 x 6 1750 RPM	
IMPELLER DIAMETER	HP
4 7/16	1/2
4 3/4	
5 3/16	
5 3/4	
6 1/8	

SERIES 3530 PUMP PERFORMANCE CURVES

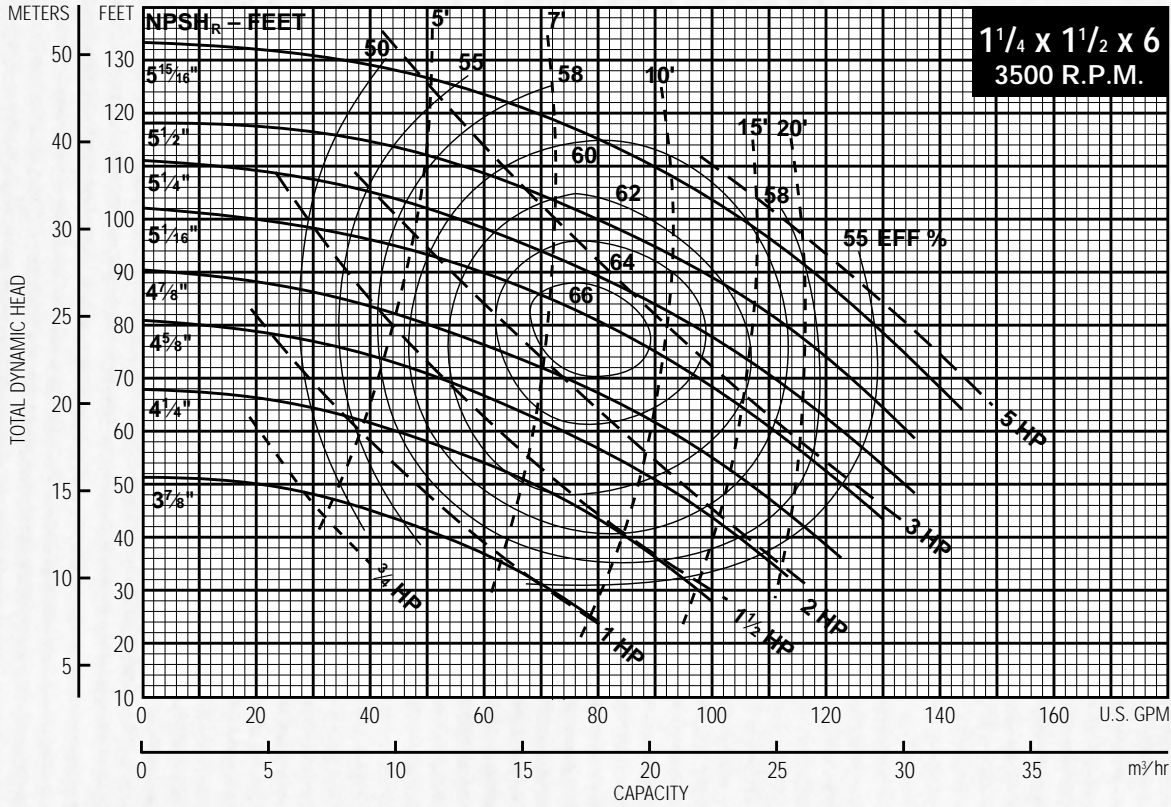

1 1/4 x 1 1/2 x 6 3500 RPM	
IMPELLER DIAMETER	HP
3 7/8	3/4
4 1/4	1
4 5/8	1 1/2
4 7/8	2
5 1/16	2 3/4
5 1/4	3
5 1/2	3 3/4
5 15/16	5

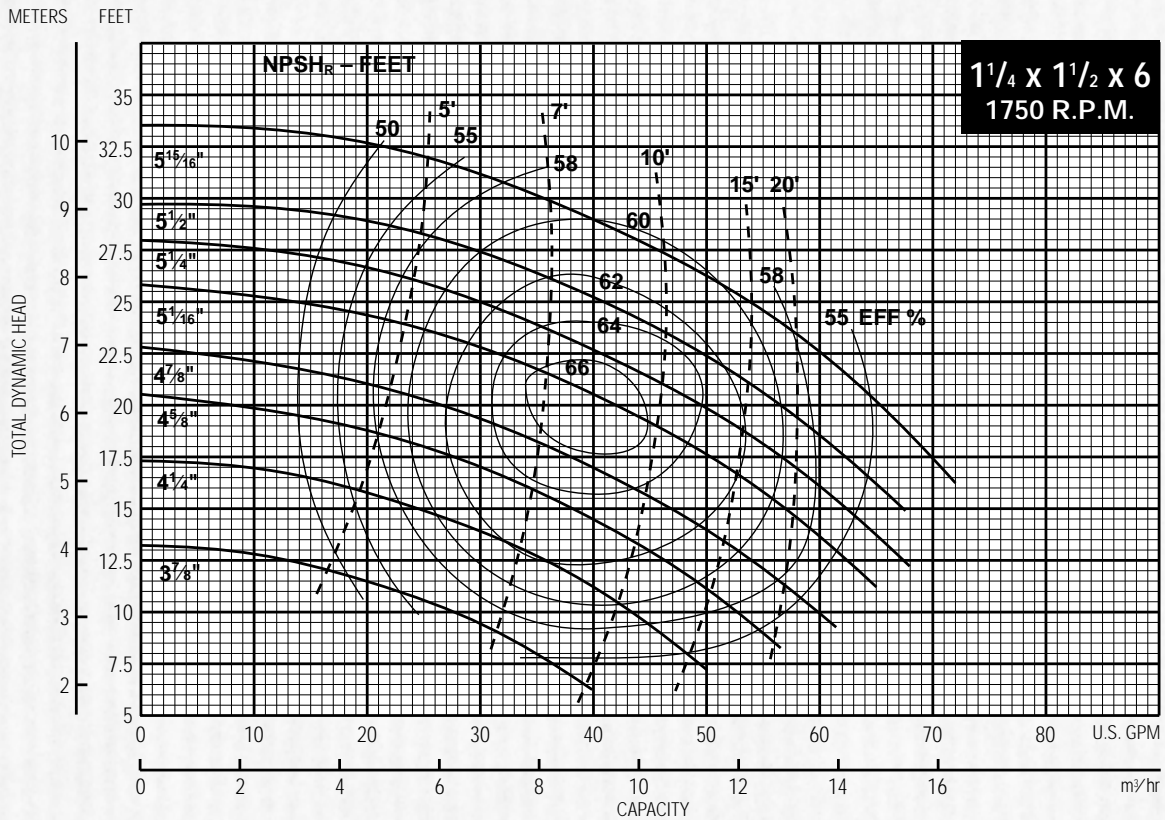

1 1/4 x 1 1/2 x 6 1750 RPM	
IMPELLER DIAMETER	HP
3 7/8	1/2
4 1/4	
4 5/8	
4 7/8	
5 1/16	
5 1/4	
5 1/2	
5 15/16	

SERIES 3530 PUMP PERFORMANCE CURVES

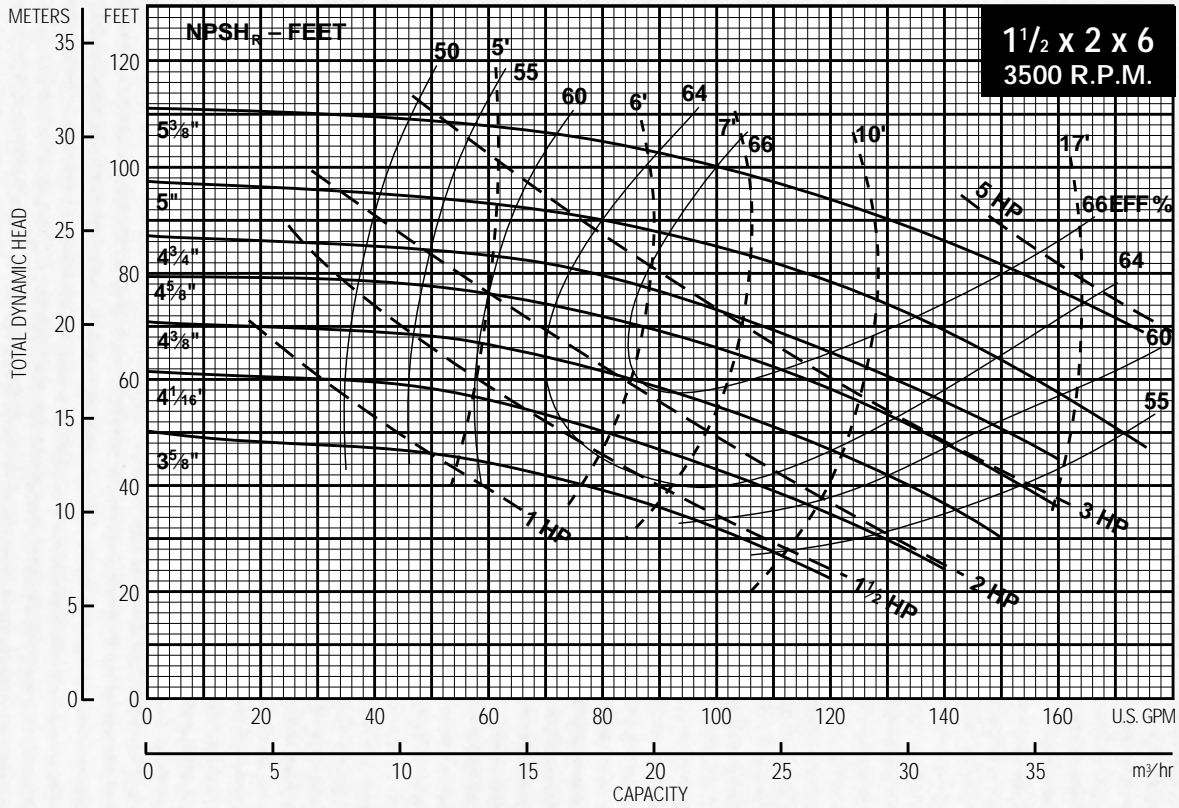

1 1/2 x 2 x 6 3500 RPM	
IMPELLER DIAMETER	HP
3 5/8"	1
4 1/16"	1 1/2
4 3/8"	2
4 3/8"	3
4 5/8"	2
4 5/8"	3
4 3/4"	3
5"	5
5 3/8"	5

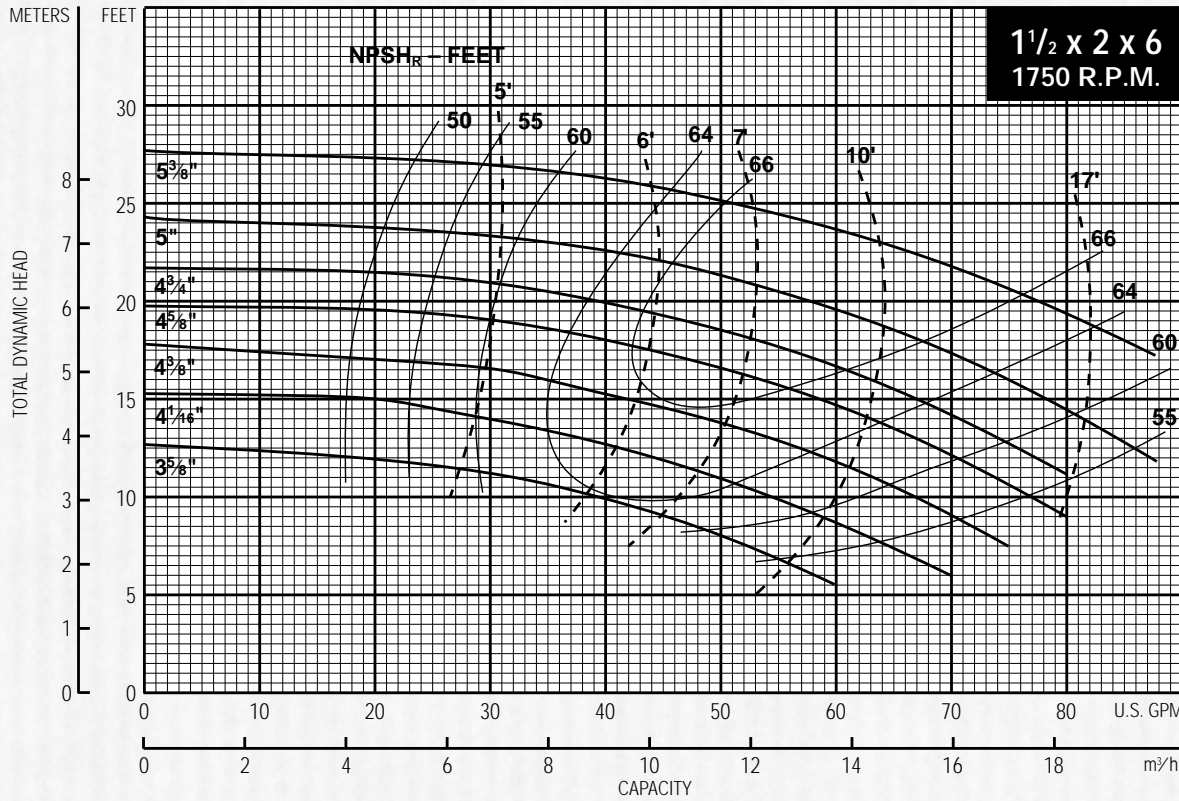

1 1/2 x 2 x 6 1750 RPM	
IMPELLER DIAMETER	HP
3 5/8"	1/2
4 1/16"	
4 3/8"	
4 5/8"	
4 3/4"	
5"	
5 3/8"	

SERIES 3530 DIMENSION - INCHES (MM)

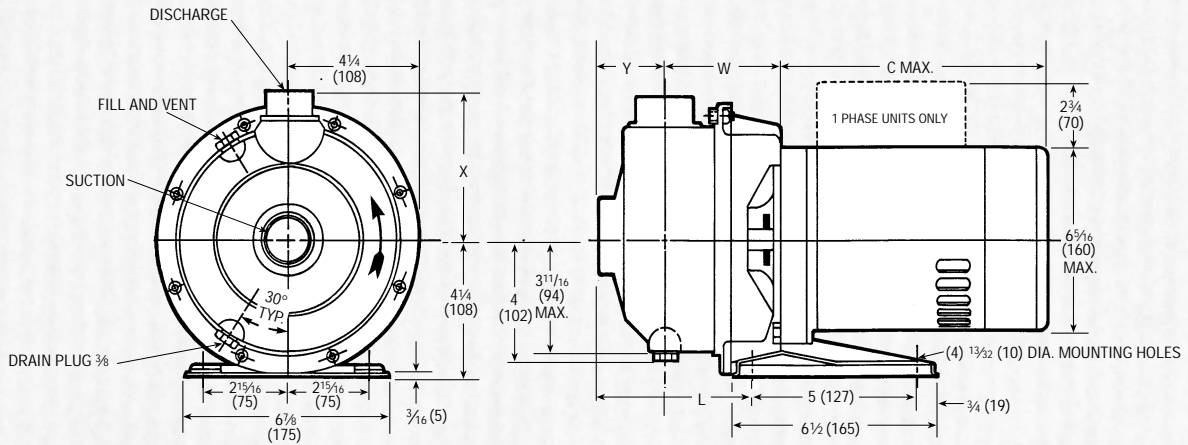

ODP and TEFC 1/2, 3/4 and 1 HP - 3500 RPM

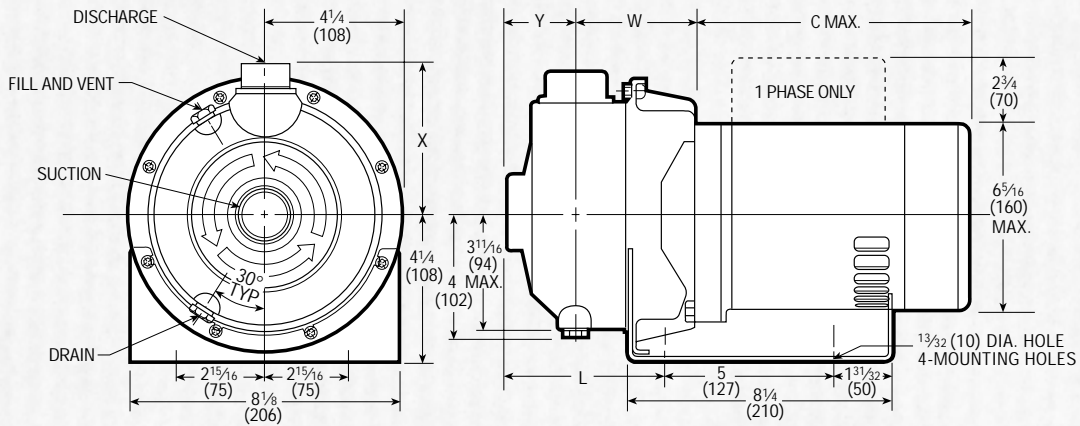

ODP and TEFC 1 1/2, 2 and 3 HP - 3500 RPM

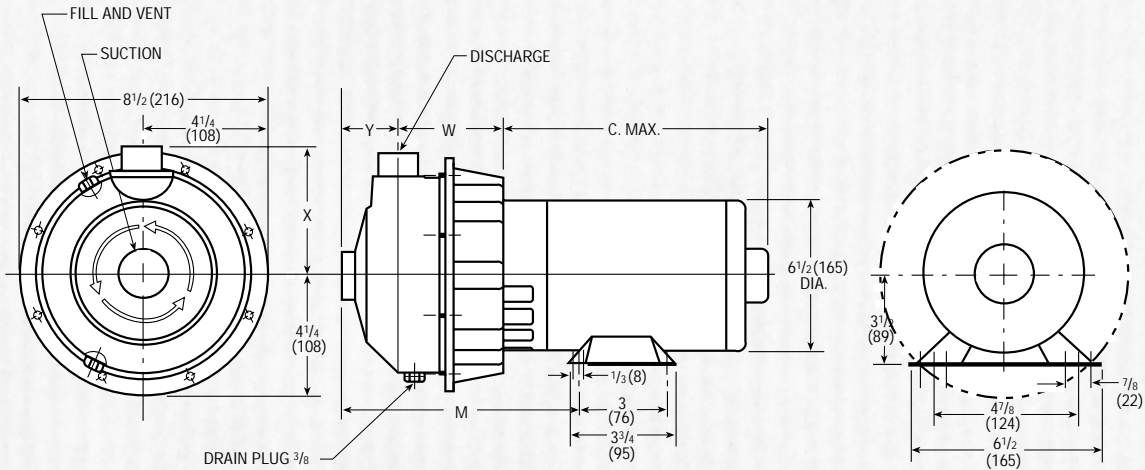

All 1750 RPM Motors and 5 HP, ODP and TEFC - 3500 RPM

Discharge	Suction	W	X	Y	L	M	C-Max.
1" NPT	1 1/4" NPT	3 5/16 (84)	4 3/8 (111)	2 (51)	4 9/16 (116)	7 5/16 (186)	12 7/16 (316)
1 1/4" NPT	1 1/2" NPT	3 3/4 (95)	4 1/2 (114)	2 1/8 (54)	5 1/8 (130)	7 7/8 (200)	14 1/4 (362)
1 1/2" NPT	2" NPT	3 3/4 (95)	4 5/8 (117)	2 1/8 (54)	5 1/8 (130)	7 7/8 (200)	14 1/4 (362)

NOTES:

1. Motor dimensions may vary with motor manufacturers.
2. Not to be used for construction purposes unless certified.

TYPICAL SPECIFICATION SERIES 3530 QUANTEK PUMPS

Furnish and install pumps with capacities as shown on plans. Pumps shall be close-coupled, single-stage, end suction design capable of being serviced without disturbing piping connections.

Pump volute and impeller shall be AISI 316L stainless steel. All casings shall have a drain and vent plug.

The liquid capacity shall be sealed off at the pump shaft by an internally-flushed mechanical seal with 316 stainless steel hardware, Viton elastomers, Carbon and Silicon Carbide faces, suitable for continuous operation at 225°F (107°C).

Pumps shall be rated for 125 PSIG (9 bar) working pressure.

The motor shall meet NEMA specifications and shall be the size, voltage and enclosure called for on the plans. It shall have rugged ball bearings, completely adequate for the maximum load for which the motor is designed. The shaft material will be 316 stainless steel.

Each pump will be hydrostatically tested per Hydraulic Institute standards. All non-stainless steel components shall be thoroughly cleaned and painted with at least one coat of high grade machinery enamel prior to shipment.

Pumps shall be Series 3530 Quantek Pumps as manufactured by ITT Bell & Gossett.

**FOR MORE INFORMATION, CONSULT YOUR LOCAL
ITT BELL & GOSSETT REPRESENTATIVE**



Bell & Gossett

USA
Bell & Gossett
8200 N. Austin Avenue
Morton Grove, IL 60053
Phone: (847) 966-3700
Facsimile: (847) 966-9052
<http://fhs.ittind.com>

INTL.
Bell & Gossett / Export Dept.
8200 N. Austin Avenue
Morton Grove, IL 60053
Phone: (847) 966-3700
Facsimile: (847) 966-8366
Cable: BELGOSSETT

CANADA
Fluid Products Canada
55 Royal Road
Guelph, Ontario,
N1H 1T1, Canada
Phone: (519) 821-1900