

NOTICE TO INSTALLER: Instructions must remain with installation.

"QUALITY PUMPS SINCE 1939"

SECTION: 6.10.125

FM1422

0806

Supersedes

1005

Product information presented here reflects conditions at time of publication. Consult factory regarding discrepancies or inconsistencies.



MAIL TO: P.O. BOX 16347 • Louisville, KY 40256-0347
SHIP TO: 3649 Cane Run Road • Louisville, KY 40211-1961
(502) 778-2731 • 1 (800) 928-PUMP • FAX (502) 774-3624

visit our web site:
www.zoeller.com

Qwik-Box Alarm System

INSTALLATION INSTRUCTIONS AND PREINSTALLATION CHECKLIST



▲ WARNING Installation of The Zoeller Qwik-Box and Alarm systems should be done by a qualified licensed electrician. All electrical and safety codes must be followed in addition to the National Electrical Code and all applicable local codes.

▲ WARNING For your protection **always** disconnect the power from the power source before installing the Qwik-Box.

PREINSTALLATION CHECKLIST

1. Inspect your "Qwik-Box" and installation accessories. See Parts List on following page. Occasionally, products are damaged during shipment. If any parts are damaged or missing, contact your dealer before starting the installation. For alarm installation instructions, see separate instructions with alarm.
2. Tether pump float control switch to provide the desired "on"- "off" point and the alarm float switch above the "on" point of the pump assembly. (See Fig. 1), or see Installation Instructions with your switch/pump.
3. "QWIK-BOX" is designed for installation either outside or inside the tank riser. Refer to Fig. 1 & Fig. 2.

OUTSIDE RISER INSTALLATION INSTRUCTIONS

1. Prepare "QWIK-BOX" for thru wall installation by solvent welding the THIN WALL PVC CONDUIT (supplied w/unit) and a 2" PVC electrical fitting (supplied by others) into "QWIK-BOX" at the appropriate end (see Fig. 1, Detail A). Install PVC conduit on the opposite end of the "QWIK-BOX" to provide for the necessary burial depth of the alarm and power cables. (See Fig. 1) Check local codes for frost line depth.
2. Remove the metal receptacle/terminal plate from the PVC box as shown in Fig. 1.
3. Apply foam tape around alarm and power cables as shown in Fig. 3(B) and push inlet cables with tape back in to the pipe as shown in Fig. 3(B). The tape must fit snugly to the inside of the conduit.
4. Secure the "QWIK-BOX" with inlet cable in place. Mix epoxy seal kit, per instructions with the epoxy seal kit and pour into the inlet. Allow 2 hours for the epoxy to cure before proceeding with the installation.

INSIDE RISER INSTALLATION INSTRUCTIONS

1. Prepare "QWIK-BOX" for inside riser installation by cutting a short section of PVC conduit of the correct length, determined by riser wall thickness plus allowances for fitting and "QWIK-BOX" sockets.
2. Remove the metal receptacle/terminal plate from the PVC box as shown in Fig. 2.
3. Pull alarm and power cables (UF cable) thru the PVC conduit Fig. 3(C), elbow, and short conduit. Strip the jacket and conductor insulation as shown in Fig. 3(B).
4. Solvent weld PVC elbow to the conduit Fig. 3(C). Apply foam tape around alarm and power cables as shown in Fig. 3(B) and push inlet cables with tape back into the pipe. The tape must fit snugly to the inside of the conduit.
5. Secure the conduit assembly with tape end up. Mix epoxy seal kit per instructions with the epoxy seal kit and pour over tape. Allow 2 hours for the epoxy sealer to cure before proceeding with the installation.
6. Install sealed conduit assembly thru the riser wall and solvent weld conduit into the "QWIK-BOX" Fig. 2.

THE FOLLOWING STEPS APPLY TO BOTH INSIDE AND OUTSIDE INSTALLATIONS

1. Connect power cable conductors to the terminal block and the grounding wire to the ground terminal, as shown in Fig. 4 and 5. Also connect the alarm cable ground wire to the grounding terminal.
2. Push the black and white alarm conductors through the small hole in the upper right hand portion of the receptacle/terminal mounting plate and connect to terminals (1) and (2) on front side of the terminal block (See Fig. 5).

*(Note: This terminal block is to be connected to a low voltage alarm source).

3. Reinstall the receptacle/terminal plate into the box covering the power cable and alarm cable.
4. Pull pump plug, piggyback float switch, and alarm float switch cables through the 2" PVC electrical fitting (supplied by others) and the THIN WALL PVC CONDUIT (supplied) into the "QWIK-BOX" See Fig. 1 Detail A for outside riser installations. Pull pump plug piggyback float switch, and alarm switch cables through the 2" PVC electrical fitting (supplied by others). Fig. 2 Detail A for inside riser installations.
5. Connect the piggyback pump control switch and pump cord into the receptacle as shown in Fig. 1 & Fig. 2. Also connect the black and white wire from the alarm float to terminals (1) and (2) on opposite side of terminal block.
6. Determine which one of the two split cord seals supplied with the "Qwik-Box" fits your application. Use P/N 018158 for pumps with cords that are 16 or 18 gauge; use P/N 018159 for pumps with 14 gauge cords.
7. Install split cord seal on the pump and float switch cords. The cord seal holes are marked with a P, F, or A - the pump cord uses the hole marked P, the piggyback switch cord uses the hole marked F, and the alarm float cord goes in the hole labeled A. The small end of the split cord seal should face the THIN WALL CONDUIT. If the control float and/or alarm float switches are not being installed, it will be necessary to plug the unused hole(s). Use the PVC rod(s) supplied with the "Qwik-Box" (See Fig. 6).
8. Insert the cord seal into the terminal adaptor and tighten hex nut until adequate strain relief is achieved.
9. Gather all ground wires, including ground conductor on the cord seal and secure to ground terminal.
10. Install alarm inside on a separate circuit as shown in Fig. 4 or 5.
11. Activate power circuits and check pump and alarm for proper operation.
12. Install cover and watertight gasket on the Qwik-Box. Install four cover screws.

(Continued on Page 3).

REFER TO WARRANTY ON PAGE 2.

LIMITED WARRANTY

Manufacturer warrants, to the purchaser and subsequent owner during the warranty period, every new product to be free from defects in material and workmanship under normal use and service, when properly used and maintained, for a period of one year from date of purchase by the end user, or 18 months from date of original manufacture of the product, whichever comes first. Parts that fail within the warranty period, one year from date of purchase by the end user, or 18 months from the date of original manufacture of the product, whichever comes first, that inspections determine to be defective in material or workmanship, will be repaired, replaced or remanufactured at Manufacturer's option, provided however, that by so doing we will not be obligated to replace an entire assembly, the entire mechanism or the complete unit. No allowance will be made for shipping charges, damages, labor or other charges that may occur due to product failure, repair or replacement.

This warranty does not apply to and there shall be no warranty for any material or product that has been disassembled without prior approval of Manufacturer, subjected to misuse, misapplication, neglect, alteration, accident or act of God; that has not been installed, operated or maintained in accordance with Manufacturer's installation instructions; that has been exposed to outside substances including but not limited to the following: sand, gravel, cement, mud, tar, hydrocarbons, hydrocarbon derivatives (oil, gasoline, solvents, etc.), or other abrasive or corrosive substances, wash towels or feminine sanitary products, etc. in all applications

other than in raw sewage pumping applications. The warranty set out in the paragraph above is in lieu of all other warranties expressed or implied; and we do not authorize any representative or other person to assume for us any other liability in connection with our products.

Contact Manufacturer at, 3649 Cane Run Road, Louisville, Kentucky 40211, Attention: Customer Service Department to obtain any needed repair or replacement of part(s) or additional information pertaining to our warranty.

MANUFACTURER EXPRESSLY DISCLAIMS LIABILITY FOR SPECIAL, CONSEQUENTIAL OR INCIDENTAL DAMAGES OR BREACH OF EXPRESSED OR IMPLIED WARRANTY; AND ANY IMPLIED WARRANTY OF FITNESS FOR A PARTICULAR PURPOSE AND OF MERCHANTABILITY SHALL BE LIMITED TO THE DURATION OF THE EXPRESSED WARRANTY.

Some states do not allow limitations on the duration of an implied warranty, so the above limitation may not apply to you. Some states do not allow the exclusion or limitation of incidental or consequential damages, so the above limitation or exclusion may not apply to you.

This warranty gives you specific legal rights and you may also have other rights which vary from state to state.

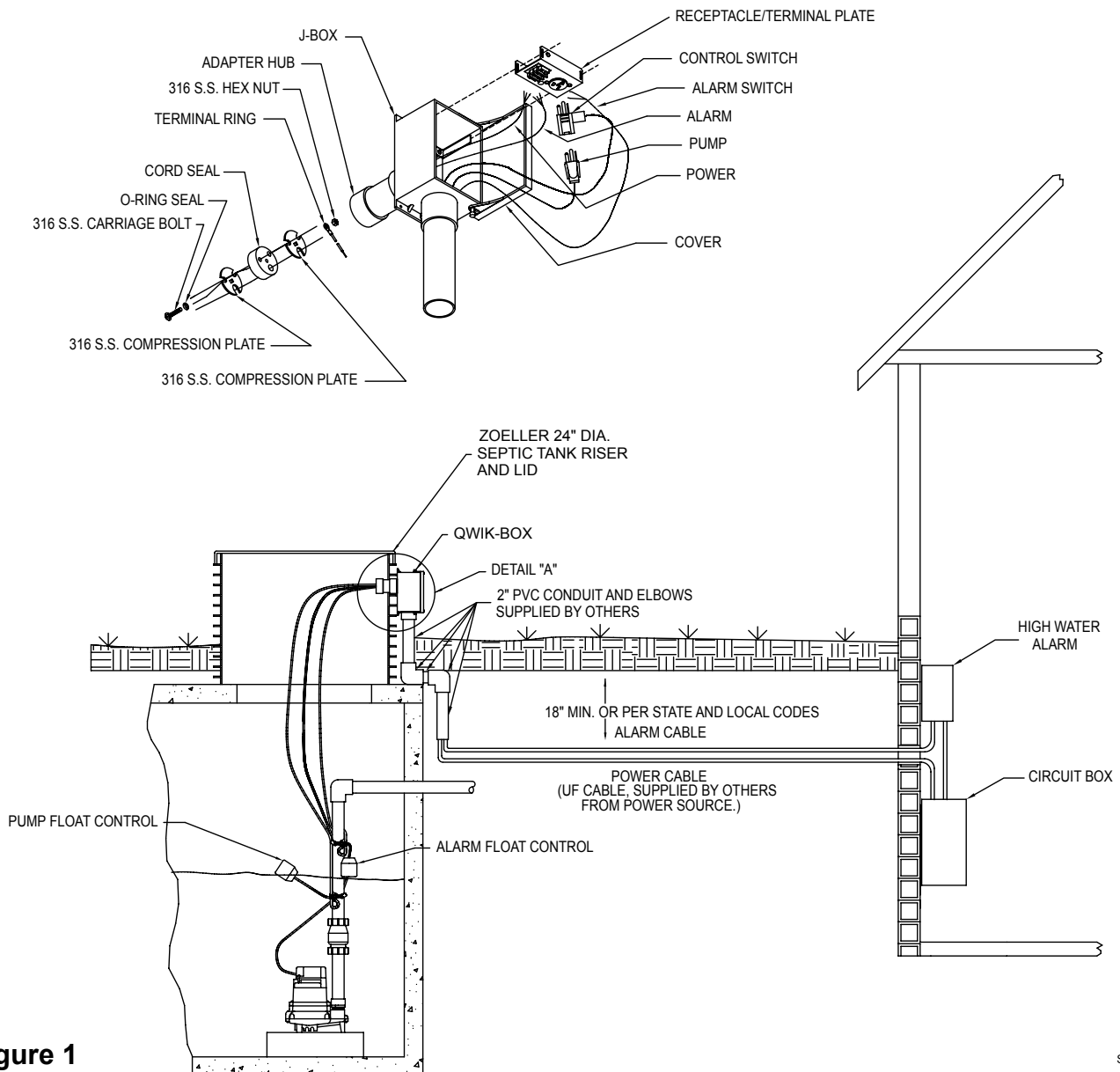

Figure 1

SK2580

PREINSTALLATION CHECKLIST (Continued)

13. Pump and control switch can now be easily removed for service or repair by removing cover and unplugging from the receptacle. | 14. For pump testing or manual operation, pump can be plugged directly into receptacle overriding the piggyback switch.

PARTS LIST

ASSEMBLY P/N	VOLT	QWIK-BOX	ALARM & FLOAT SW	PUMP CONTROL SW	CORD SEAL	EPOXY SEAL KIT	SEAL TAPE
10-0568 ⁽¹⁾	115V	010142	10-1494	10-0034	011769	008897	010079
10-0569 ⁽¹⁾	230V	010143	10-1494	10-0035	011769	008897	010079
10-0566 ⁽¹⁾	115V	010142	N/A	10-0034	011769	008897	010079
10-0567 ⁽¹⁾	230V	010143	N/A	10-0035	011769	008897	010079
10-0579 ⁽²⁾	115V	010142	N/A	N/A	011769	008897	010079
10-0580 ⁽²⁾	230V	010143	N/A	N/A	011769	008897	010079
10-0592 ⁽²⁾	115V	010142	10-1494	N/A	011769	008897	010079
10-0593 ⁽²⁾	230V	010143	10-1494	N/A	011769	008897	010079

(1) For use with pumps rated 1/2 HP, 115V, 13 AMPS or 1 HP, 230V, 13 AMPS.

(2) For use with pumps rated 13-15 AMPS, 3/4 HP, 115V or 13-20 AMPS, 2 HP, 230V, order switch separately. See FM0477. (Pumps must have 15 Amp plug cap to be used with piggyback switch.)

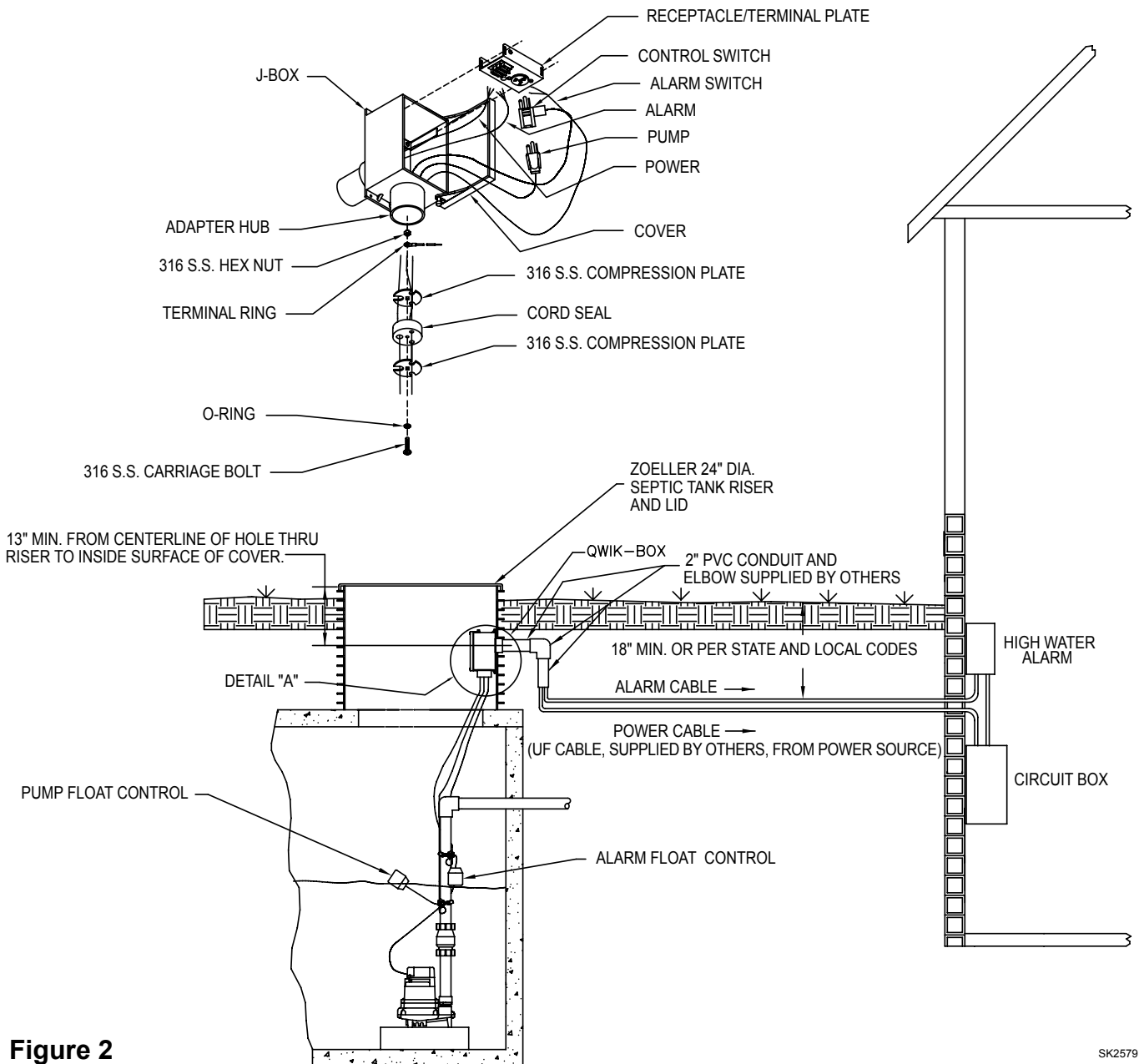

Figure 2

SK2579

UF Cable Strip Length Foam Tape Placement

OUTSIDE INSTALLATION

APPLIES TO INSIDE AND OUTSIDE INSTALLATIONS

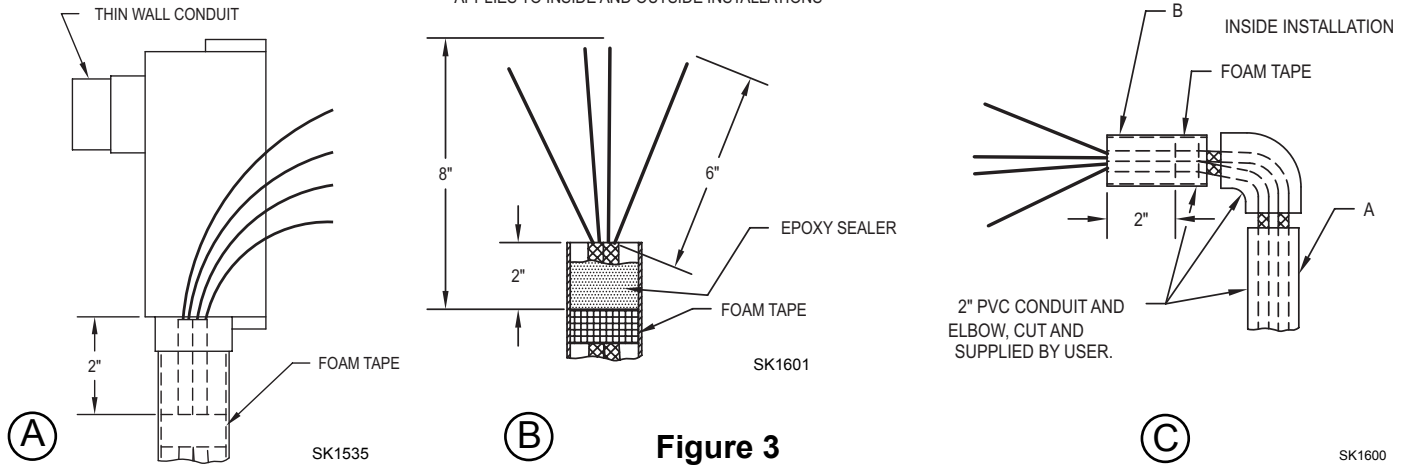

Figure 3

Wiring Topside Receptacle Bracket

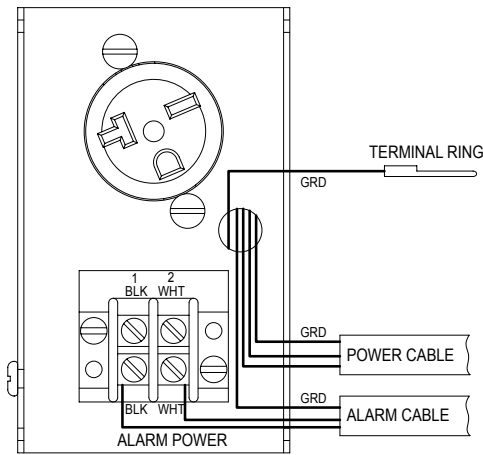

Figure 4

SK2578B

Wiring Underside Receptacle Bracket

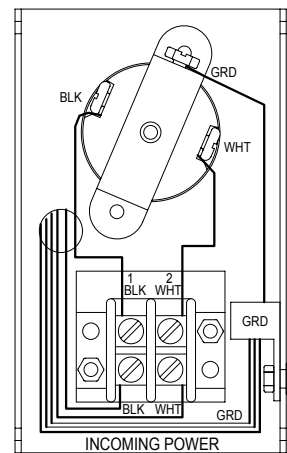

Figure 5

SK2578A

Split Cord Seal/ Hose Clamp Installation

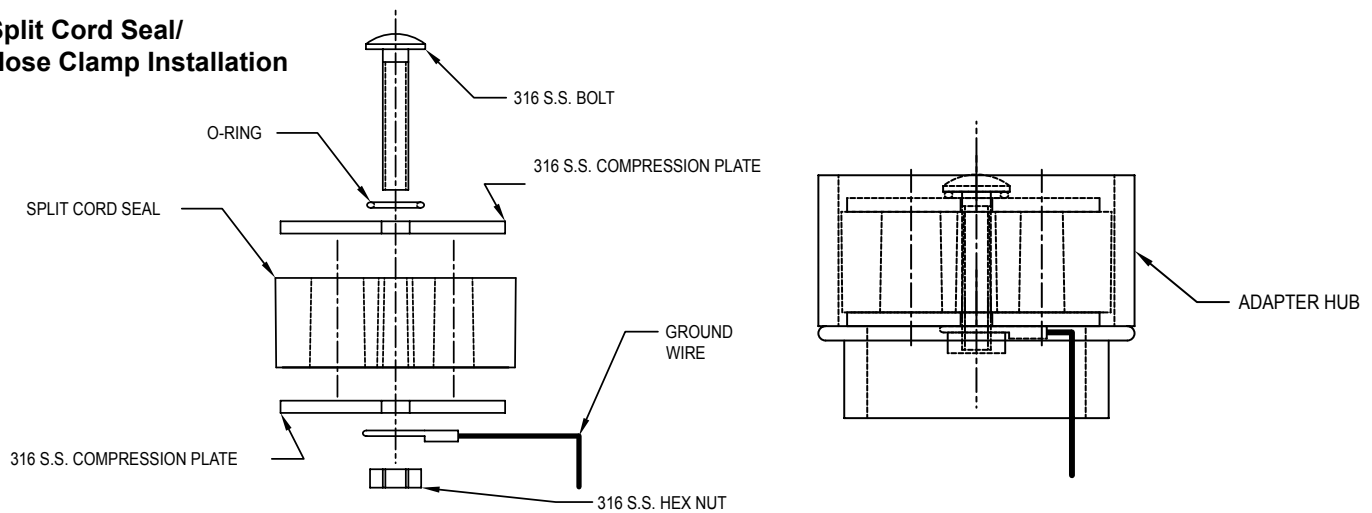

Figure 6

SK2577



www.zoeller.com

ZOELLER
PUMP CO.

MAIL TO: P.O. BOX 16347
Louisville, KY 40256-0347
SHIP TO: 3649 Cane Run Road
Louisville, KY 40211-1961
(502) 778-2731 • 1 (800) 928-PUMP
FAX (502) 774-3624

Manufacturers of..

"QUALITY PUMPS SINCE 1939"