

Notice to Installer: Instructions must remain with installation.

"QUALITY PUMPS SINCE 1939"

Product information presented here reflects conditions at time of publication. Consult factory regarding discrepancies or inconsistencies.

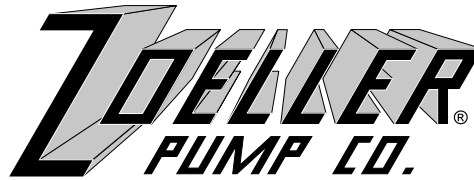

SECTION: 6.10.150

FM2337

0509

Supersedes

1107

MAIL TO: P.O. BOX 16347 • Louisville, KY 40256-0347
SHIP TO: 3649 Cane Run Road • Louisville, KY 40211-1961
(502) 778-2731 • 1 (800) 928-PUMP • FAX (502) 774-3624

visit our web site:
www.zoeller.com

Pressure Booster System Models 353 & 354 INSTALLATION INSTRUCTIONS

These installation instructions are applicable for Models 353 & 354 Pressure Booster Pumps Only







PREINSTALLATION CHECKLIST - ALL INSTALLATIONS

ATTENTION: READ CAREFULLY BEFORE ATTEMPTING TO INSTALL OR OPERATE YOUR PUMP. PROTECT YOURSELF AND OTHERS BY OBSERVING ALL SAFETY INFORMATION AND ADDITIONAL INSTRUCTIONS INCLUDED WITH EQUIPMENT. FAILURE TO COMPLY WITH INSTRUCTIONS COULD RESULT IN PERSONAL INJURY AND/OR PROPERTY DAMAGE! RETAIN FOR FUTURE REFERENCE.



WARNING

SEE BELOW FOR LIST OF WARNINGS

1. Make sure that the pump is plugged into a properly grounded electrical receptacle. Use an Underwriters Laboratory listed circuit analyzer to test for proper installation of the circuit and ground. Any service to circuits or receptacles should be conducted by a qualified licensed electrician.
2. All electrical installations must conform to the requirements of the National Electrical Code and all local codes.
3. It is strongly recommended that the unit be plugged into a GFCI protected circuit.
4. Disconnect power before servicing the pump or motor by unplugging the unit from the outlet.
5.  Do not touch the motor when operating and allow the motor to cool before touching.
6. Pump is built to handle clear water only; it is not designed to handle water containing sand, silt or other abrasives.
7.  Do not use to pump flammable or explosive fluids such as gasoline, fuel oil, kerosene, etc. Do not use in flammable and/or explosive atmospheres.
8.  Do not use this product in hazardous environments or anywhere a spark could potentially ignite explosive gases.
9. Do not handle this product with wet hands or while standing in water or on a wet or damp surface.
10. Units are supplied with an automatically resetting thermal overload device and can restart without warning.
11.  Provide a means of pressure relief if the pump discharge can be shut off or obstructed. Pumps operating against a closed discharge can create very hot pumped liquid, which can cause burns.
12. Do not install unit outdoors. This unit is not weatherproof nor is it able to be submerged in water or any other liquid.
13. Do not ground to a gas supply line.
14.  Hazardous voltage. Can shock, burn or cause death. Ground pump before connecting to power supply.
15.  Hazardous pressure! Install pressure relief valve in discharge pipe. Release all pressure on system before working on any component.
16. According to the state of California (Prop 65), this product contains chemicals known to the state of California to cause cancer and birth defects or other reproductive harm.
17. Risk of Electric Shock. This pump has not been investigated for use in swimming pool areas.
18. Use only components that are rated for maximum pressure pump can produce when used in boosting system or any other system. Do not exceed the total maximum pressure boost as listed per model in Performance Chart A.
19. Never examine, make wiring changes or touch the motor before disconnecting the main electrical supply switch. The thermal device may have opened the electrical circuit. All motors should be equipped with a correctly fused disconnect switch to provide protection. Consult local or United States National Electrical Codes for proper fuse protection based on motor data chart (See Chart B).

CAUTION

SEE BELOW FOR LIST OF CAUTIONS

1. Make certain that the power source conforms to the requirements of the equipment as stated on the product nameplates and wire motor for correct voltage. See Chart B of this manual, and motor nameplate.
 2. Check hoses for weak or worn conditions before use and make certain that all connections are secure.
 3. Periodically inspect the pump for damage and perform routine maintenance as required.
 4. The maximum temperature of the pumped liquid must not exceed 120°F. The minimum allowable temperature is 40°F.
 5. Support pump and piping when assembling and when installed. Failure to do so may cause piping to break, pump to fail, motor bearing failures, etc.
 6. This unit is not waterproof and is not intended to be used in showers, saunas or other potentially wet locations. The motor is designed to be used in a clean dry location with access to an adequate supply of cooling air. Ambient temperature around the motor should not exceed 149°F (65°C).
 7. Supply voltage must be within $\pm 10\%$ of nameplate voltage. Incorrect voltage can cause fire or seriously damage motor and voids warranty. If in doubt, consult a licensed electrician.
 8. Use wire size specified in wiring Chart B. Make certain that the power supply conforms to the electrical specifications of the motor supplied. See Motor Data Chart B. Connect pump to a separate branch circuit with no other appliances on it. If motor wiring diagram differs from diagram shown below, follow diagram on motor.
- NOTE: Pumps with the "CSA-CUS" mark are tested to UL standard UL778 and certified to CSA standard C22.2 No. 108.

REFER TO WARRANTY ON PAGE 2.

LIMITED WARRANTY

Manufacturer warrants, to the purchaser and subsequent owner during the warranty period, every new product to be free from defects in material and workmanship under normal use and service, when properly used and maintained, for a period of one year from date of purchase by the end user, or 18 months from date of original manufacture of the product, whichever comes first. Parts that fail within the warranty period, one year from date of purchase by the end user, or 18 months from the date of original manufacture of the product, whichever comes first, that inspections determine to be defective in material or workmanship, will be repaired, replaced or remanufactured at Manufacturer's option, provided however, that by so doing we will not be obligated to replace an entire assembly, the entire mechanism or the complete unit. No allowance will be made for shipping charges, damages, labor or other charges that may occur due to product failure, repair or replacement.

This warranty does not apply to and there shall be no warranty for any material or product that has been disassembled without prior approval of Manufacturer, subjected to misuse, misapplication, neglect, alteration, accident or act of God; that has not been installed, operated or maintained in accordance with Manufacturer's installation instructions; that has been exposed to outside substances including but not limited to the following: sand, gravel, cement, mud, tar, hydrocarbons, hydrocarbon derivatives (oil, gasoline, solvents, etc.), or other abrasive or corrosive substances, wash towels or feminine sanitary products, etc. in all pumping applications. The warranty set out in the paragraph above is in lieu of all

other warranties expressed or implied; and we do not authorize any representative or other person to assume for us any other liability in connection with our products.

Contact Manufacturer at, 3649 Cane Run Road, Louisville, Kentucky 40211, Attention: Customer Service Department to obtain any needed repair or replacement of part(s) or additional information pertaining to our warranty.

MANUFACTURER EXPRESSLY DISCLAIMS LIABILITY FOR SPECIAL, CONSEQUENTIAL OR INCIDENTAL DAMAGES OR BREACH OF EXPRESSED OR IMPLIED WARRANTY; AND ANY IMPLIED WARRANTY OF FITNESS FOR A PARTICULAR PURPOSE AND OF MERCHANTABILITY SHALL BE LIMITED TO THE DURATION OF THE EXPRESSED WARRANTY.

Some states do not allow limitations on the duration of an implied warranty, so the above limitation may not apply to you. Some states do not allow the exclusion or limitation of incidental or consequential damages, so the above limitation or exclusion may not apply to you.

This warranty gives you specific legal rights and you may also have other rights which vary from state to state.

TROUBLE SHOOTING GUIDE



▲ WARNING

ELECTRICAL PRECAUTIONS - Before servicing a pump, always shut off the main power breaker and then unplug the pump. Make sure you are not standing in water and are wearing insulated protective sole shoes. Under flooded conditions, contact your local electric company or a qualified licensed electrician for disconnecting electrical service prior to pump removal.

Symptom	Possible Cause(s)	Corrective Action
Pump won't start or run at full speed.	<ol style="list-style-type: none"> Blown fuse or open circuit breaker. Power supply in OFF position. Incorrect voltage at motor (check voltage with motor running). Loose, broken or incorrect wiring. Defective motor. Pump hydraulic components clogged/worn/damaged. 	<ol style="list-style-type: none"> Replace fuse or close circuit breaker. See wire size chart for proper breaker/fuse size. Turn power on. Low voltage. <ol style="list-style-type: none"> Voltage must be within $\pm 10\%$ of motor rated voltage. Check incoming voltage. Contact power company. Make certain that voltage of motor matches voltage of power supply. See motor name plate and motor wiring diagrams. Check wire size from main switch to pump. See wire size chart for correct wire size. Rewire any incorrect circuits. Tighten connections, replace defective wires. Replace motor. Replace worn parts or entire pump. Clean parts if required.
Pump operates, but delivers little or no water.	<ol style="list-style-type: none"> Manual or solenoid valves plumbed into system restricting flow. In-line filter restricting flow. Low line voltage. Inadequate water supply to booster pump. Undersized piping. Leak on inlet side of system. Worn or defective pump parts or pump. Suction lift too great. Pump not primed. 	<ol style="list-style-type: none"> <ol style="list-style-type: none"> Check all valves on pump inlet and discharge sides of system to be sure they are opened properly to allow flow to and from the pump. Bleed trapped air in pump which keeps water from reaching the pump. (Normally due to closed valve in discharge plumbing). Check all in-line filters to be sure they are not plugged or restricted. See low line voltage corrective action (above). Check pressure on inlet side of booster to be sure positive pressure is maintained to the booster pump. Replace undersized piping. Make sure connections are tight. Repair leaks as necessary. Replace worn parts or entire plugged impeller. Clean parts if required. Pump should be operated under flooded suction only. Prime pump - Make certain inlet pipe is drawn up tight and pump and pipe are full of water.
Excessive noise while pumping.	<ol style="list-style-type: none"> Pump not secured to firm foundation. Piping not supported. Restricted inlet line. Cavitation (noise like marbles in pump). Worn motor bearings. 	<ol style="list-style-type: none"> Secure properly. Make necessary adjustments. Clean or correct. Increase inlet pipe size. Replace bearings or motor.
Pump leaks.	<ol style="list-style-type: none"> Worn mechanical seal (leaks at shaft). Worn o-ring seals. 	<ol style="list-style-type: none"> Replace shaft (rotary) seal. Replace o-ring seals, located inside both ends of the stainless steel shell.

DESCRIPTION

Figure 1

Pressure booster pumps increase water pressure from city mains or private water systems. This system is powered by a 1/2 or 3/4 HP single phase, capacitor start motor with thermal overload protection. The bladder tank is pressurized with air to 48 PSI.
NOTE: Use pump with clear water only.

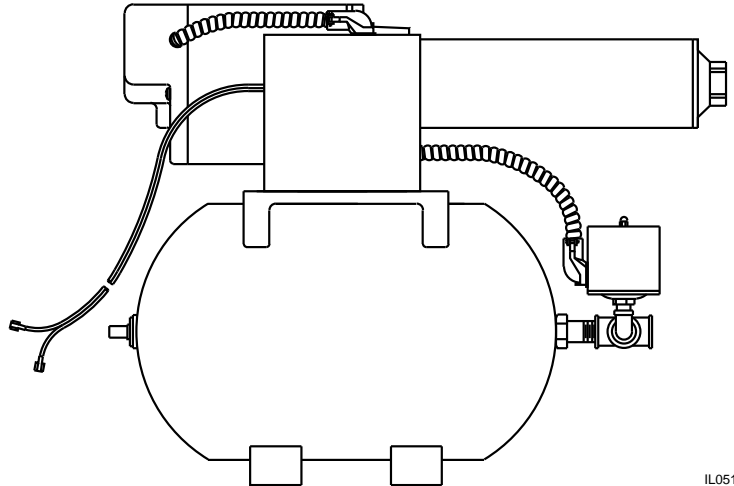

IL0516

SPECIFICATIONS

Chart A: Performance Specifications based on 20 PSI flooded suction

Gallons per Minute				20	18	15	14	12	10	8	6	4	3	Max. Press. PSI	Suction Pipe Tap NPT	Disch. Pipe Tap NPT
S.S. Pump w/ S.S. Tank	S.S. Pump w/ Painted Tank	HP	Stage	Discharge PSI												
353-0006	353-0005	1/2	3	42	46	52	54	57	60	61	62	63	64	66	1"	1"
354-0006	354-0005	3/4	4	55	60	64	66	70	72	73	75	76	76	79	1-1/4"	1"

To keep pump and seal lubricated, a minimum flow of 1.5 GPM must always be maintained through the pump.
 Motor voltage: Single phase 1/2 - 3/4 HP - 115V, 60 Hz.

Chart B: 115V, 60 Hz Motor Data & Minimum Wire Size (Gauge)

Motor HP	Service Factor Motor Amps	Phase†	Distance In Feet From Motor To Service Panel					Breaker Size (Amps)
			0-50	50-100	100-150	150-200	200-300	
			Wire Size					
1/2	13.0	1	12	12	12	12	10	20
3/4	14.0	1	12	12	12	10	8	20

†Thermal overload protector - automatic reset.

Chart C: Material Construction

Component	Description
Motor	Rear access - Nema 56J face
Bearings	Ball-ball, permanently lubricated
Impellers	Noryl with 304 stainless steel bearing insert
Diffuser	Noryl
Diffuser plates	Delrin
Pump shaft	304 Stainless steel
Pump shaft coupling	304 Stainless steel
Pump shell	304 Stainless steel
Discharge & inlet casting	304 Stainless steel
O-Rings	Viton
Seal composition	Carbon-ceramic, stainless steel spring and Viton

SAFETY INSTRUCTIONS

Carefully read and follow all safety instructions in this manual and on pump. Keep safety labels in good condition. Replace missing or damaged safety labels.



This is a SAFETY ALERT SYMBOL. When you see this symbol on the pump or in the manual, look for one of the following signal words and be alert to the potential for personal injury or property damage.

▲ DANGER Warns of hazards that WILL cause serious personal injury, death or major property damage if ignored.

▲ WARNING Warns of hazards that CAN cause serious personal injury or death, if ignored.

▲ CAUTION Warns of hazards that MAY cause minor personal injury, product or property damage if ignored.

IMPORTANT: Indicates factors concerned with operation, installation, assembly or maintenance which could result in damage to the machine or equipment if ignored.

NOTE: Indicates special instructions which are important but are not related to hazards.

GENERAL

1. Wear safety glasses when working with pumps.
2. Periodically inspect pump and system components.
3. Protect electrical cord. Replace or repair damaged or worn cords immediately.
4. Do not insert finger or any object into pump or motor openings.

LOCATION

1. Locate pump as close to the fluid source as possible, keeping the inlet pipe short as possible.

2. Place unit where the pump and piping are protected from the weather and extremes of heat, humidity and below freezing temperatures.
3. Mount unit in a dry location that is easily accessible for inspection and maintenance. If a dry location is not available, mount it on a foundation well above the wet floor.
4. Allow ample clearance around unit for free air circulation.

SUCTION LIMITATIONS

1. Units are non self-priming.
2. Pressure booster pumps are not recommended for suction lift applications.

PIPING

1. Use galvanized piping, rigid plastic or other suitable pipe that will not collapse under suction or rupture due to pressure.

▲ CAUTION If hose is used, make sure it is the reinforced industrial type that is rated higher than the shutoff pressure of the system. Ordinary garden hose will collapse and starve the pump of water.

2. The diameter of the inlet and discharge pipe should be no smaller than the corresponding ports of the pump (See Chart A). Smaller pipe will reduce the capacity of the pump.
3. Avoid air pockets in inlet piping or air will accumulate at high points, making priming difficult.
4. Use pipe compound on all joints and connections. Use Teflon tape or plastic joint stik, on plastic pipe.

IMPORTANT: The entire system must be air and water tight for efficient/ proper operation.

IMPORTANT

Figure 2 - No Air Pockets in Inlet Pipe

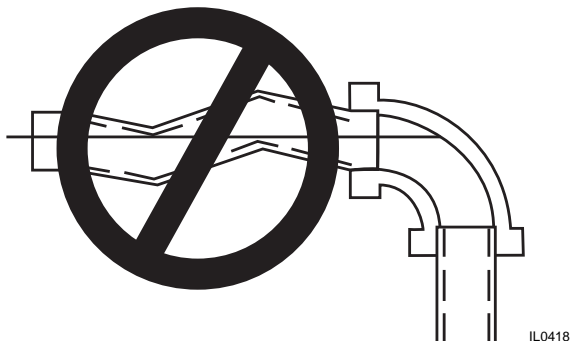
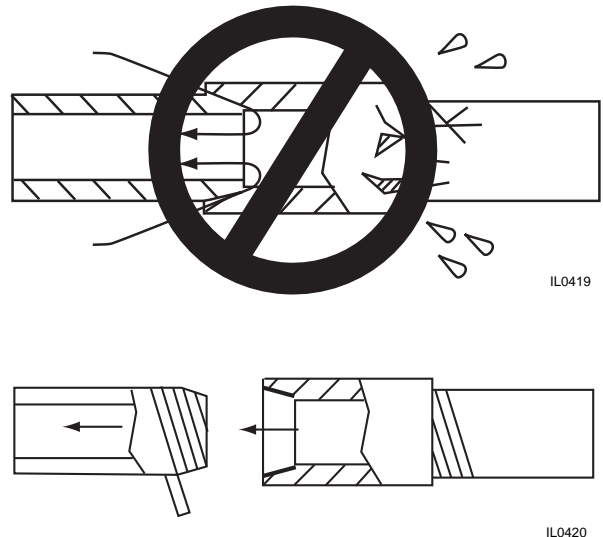

Figure 3 - Inlet Pipe Must Not Leak



INSTALLATION

IMPORTANT: Pump is built to handle clear water only; it is not designed to handle water containing sand, silt or other abrasives.

1. Refer to Figure 4 for typical installations.

CAUTION To reduce the chance of water hammer, do not use swing/flapper type check valves. A spring-loaded or similar type check valve is recommended.

2. Bolt pressure booster system to a secure foundation.

3. Locate the pump so that there will always be a positive supply of water to the pump (See Figure 4).

4. For service convenience, the installer is recommended to add gate valves and unions as needed to provide for easier maintenance.

5. Pressure gauges on the inlet and outlet, provided by the installer, are recommended to show if sufficient water is being supplied to the pump and to show service pressure.

WIRING

1. Install ground wire and maintain this pump in accordance with your local electrical code and all other codes and ordinances that apply. Consult your local building inspector for local code information.

IMPORTANT: Check local and/or United States National Electrical Codes for proper grounding information. Do not ground to a gas supply line.

2. Connect ground wire first; then to grounding terminal provided on the control box, identified as GRD or \perp . Ground connection MUST be made to this terminal. Do not connect motor to electrical power supply until unit is permanently grounded; otherwise serious or fatal electrical shock hazard may result.

3. Connect the other end of the ground wire to a properly grounded service panel or to a control panel ground bar if it is connected to the power supply ground.

4. Connect the two red wires from the control box into the two black and orange wires on the flow sensor.

5. Specific Wiring Procedure (Refer to Figure 5 and Minimum Wire Size Chart B).

a. The 1/2 and 3/4 HP single phase pumps are factory connected for 115V at the motor.

b. The motor wiring diagram in Figure 5 is located on the motor label of the pump.

WARNING Replace rear access cover before starting or operating pump. Failure to do so can result in personal injury.

IMPORTANT: Do not use an extension cord or splice wires. Joints should be made in an approved junction box. If the above information or the following wiring diagrams are confusing, consult a licensed electrician.

MOTOR PROTECTION

All single phase motors have built in thermal protection for all voltages. The overload protects the motor against burnout from overload of low voltage, high voltage and other causes. The device is automatic and resets itself once the temperature has dropped to a safe point. Frequent tripping of the device indicates trouble in the motor or power lines and immediate attention is needed.

CAUTION Disconnect power supply and depressurize system before servicing pump or removing any component.

Figure 4 - Pump used to boost incoming city pressure (automatic operation).

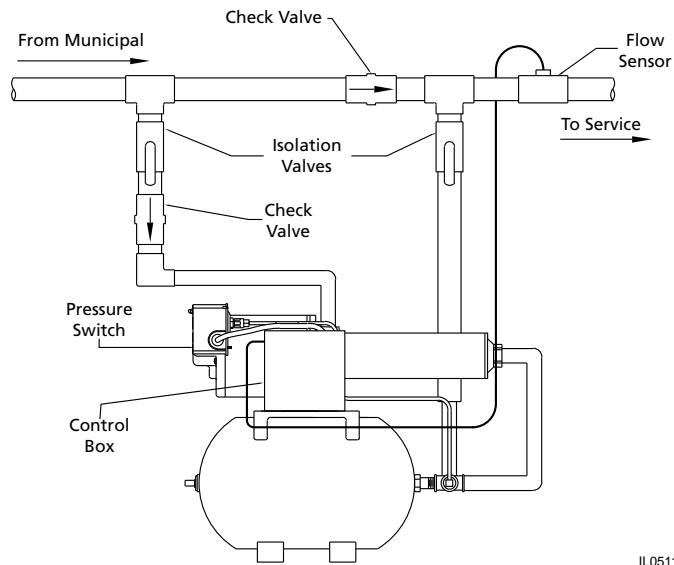

IL0511

Figure 5 - Wiring Diagram for Single Phase 1/2 - 3/4 HP Motors

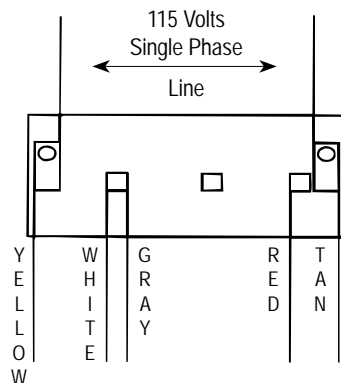

IL0180

Figure 6 - Control Box

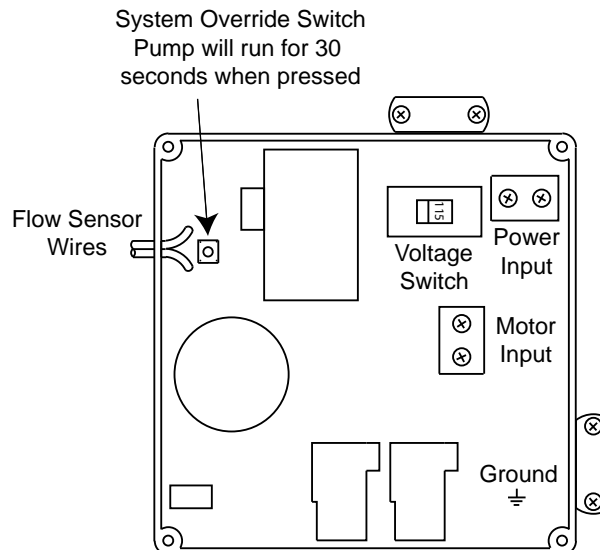

IL0512

OPERATION

▲ CAUTION Unit must be full of water before operating. Do not run dry, or against a closed discharge. Do not pump dirty water or abrasive liquids. To do so will cause pump failure and will void the warranty.

VALVES

The inlet and outlet isolation valve should be in the full open position.

PRIMING

NOTE: Before starting the pump it is absolutely necessary that both the pump and the inlet pipe be completely filled with water.

PRESSURE BOOST INSTALLATIONS

Priming is automatic when pump is connected to a pressure source such as a hydrant or city main (See Figure 4).

1. Open the valves or nozzles on inlet and discharge side of pump.
2. To relieve trapped air, allow water supply to run a minimum of 30 seconds before starting the pump. (See Figure 4).

IMPORTANT: An adequate flow of water (1.5 GPM min.) going into the pump is required so that the pump impellers and shaft seal do not run dry and fail.

3. If you installed a pressure gauge at the pump inlet, a reading of 2 PSI minimum should show whenever the pump is in operation. This reading insures that there is an ample supply of water into the pump inlet housing.

4. The controller, flow sensor and pressure switch continuously monitor water pressure and flow (See Figure 4). The system automatically turns the unit off if pressure reaches 70 to 72 PSI. The control package also protects the unit from dry run by shutting down in 30 seconds if water usage drops below 1 gallon per minute.

Figure 7 - Correct Motor/Pump Rotation (all units)

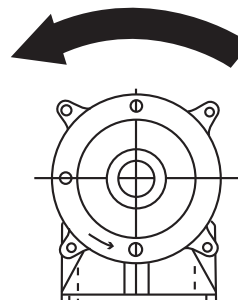

IL0513

START - UP PROCEDURE

Once the preceding instructions have been completed, the pump can be started.

1. During the first few hours of operation, inspect the pump, piping and any auxiliary equipment used in connection with the unit.
2. Check for leaks, excessive vibration or unusual noises.
3. As stated in #4 above, the booster unit will turn on and off automatically, based on water usage.

MAINTENANCE

ROUTINE

Pump should be checked routinely for proper operation. Replace or clean any filters and line strainers that may be installed on a regular basis.

DRAINING

This pump cannot be completely drained because of internal design. Most of the liquid can be drained by tilting the discharge forward after removing discharge casting; or, the liquid can be drained through the inlet port. Store in heated areas.

LUBRICATION

The motor has prelubricated bearings. No lubrication is required.

PUMP DISASSEMBLY

To disassemble the pump, refer to the exploded parts view, Figure 11.

Tools Required

- Block of wood (2" x 4" x 12")
- Piece of 3/4" pipe (12" to 24" long)
- Pipe wrench
- Strap wrench
- 1/4" Dowel rod (about 24" long)
- 9/16" Open end wrench
- 3/8" Open end wrench

1. To stabilize pump during disassembly, place block of wood underneath pump barrel.
2. Thread pipe into pump inlet port. This acts as a handle.
3. Using the pipe wrench, remove the discharge head, turning CCW (counter clockwise).

4. With the strap wrench, loosen the barrel, turning CCW (counter clockwise). DO NOT use pipe wrench on pump barrel.
5. Holding the impeller stack in place, position pump in upright position, standing unit on the motor end cover.
6. Use the 1/4" dowel rod to hold the stages down and in place on the pump shaft. Remove pump barrel.
7. Slide the stages off the pump shaft onto the 1/4" dowel rod. Leave stages on rod and carefully set aside.

NOTE: There may be some small .010" shim washers located next to the pump shaft coupling. Keep these shims for re-assembly.

8. Through the side opening of the mounting frame, hold the motor shaft with 9/16" wrench. Remove the shaft and coupling from the motor using the 3/8" wrench on the hex shaped pump shaft.

NOTE: If the hex shaft comes free, leaving the coupling attached to the motor, use vise grips to free the coupling.

Figure 8 - Remove mechanical seal.

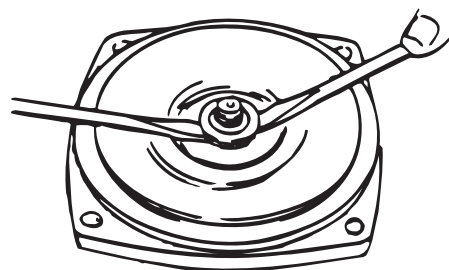

IL0173B

MAINTENANCE (continued)

MECHANICAL SEAL REPLACEMENT

1. Follow instructions under "Pump Disassembly".
2. Remove the mechanical seal assembly.
 - a. The rotary portion of the seal assembly (carbon ring, Buna-N gasket and spring will slide easily off the end of shaft).
 - b. Using two (2) screwdrivers, pry the ceramic seal and rubber gasket from the recess of the mounting ring (See Figure 8).

CAUTION The precision lapped faces of the mechanical seal are easily damaged. Handle the replacement seal carefully. Short seal life will result if seal faces (ceramic & carbon) are nicked, scratched or dirty.

3. Clean the seal cavity of the mounting ring and the motor thoroughly.
4. Wet outer edge of rubber cup on ceramic seat with liquid soap solution. Use sparingly (one drop only).

NOTE: Liquid soap solution - one drop of liquid soap combined with one teaspoonful of water.

Figure 9 - Press in seal.

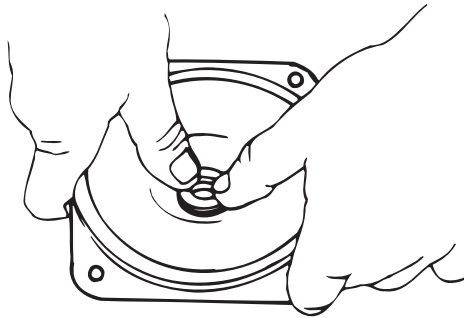

IL0168A

5. With thumb pressure, press ceramic seal half firmly and squarely into seal cavity. Polished face of ceramic seat is up. If seal will not seat

Figure 10 - If necessary, press with cardboard and pipe.

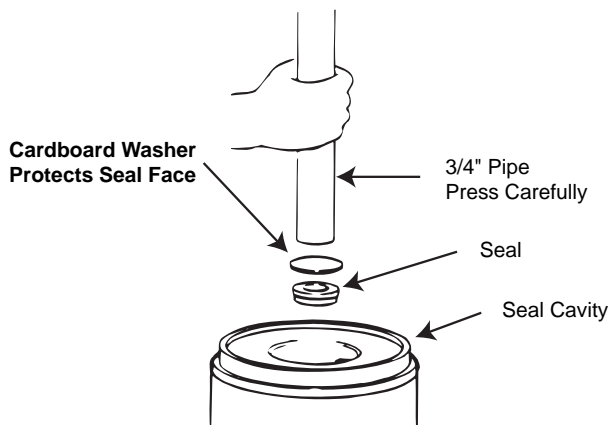

IL0169A

6. If seal does not seat correctly after recleaning cavity, place a cardboard washer over polished seal face and carefully press into place using a piece of standard clean 3/4" pipe as a press (See Figure 10).
7. Dispose of cardboard washer and recheck seal face to be sure it is free of dirt, foreign particles, scratches and grease.
8. Inspect shaft to be sure it is free of nicks and scratches.
9. Apply liquid soap solution sparingly (one drop is sufficient) to inside diameter of rubber rotating member.
10. Slide rotating seal member (carbon face down toward ceramic face) and spring over the shaft.

MOTOR REPLACEMENT

The motor can be replaced with any standard Nema 56J jet pump motor (of proper HP for each pump) by referring to the following instructions.

1. Follow steps as outlined under Rotary Seal Replacement and Pump Disassembly.
2. Remove cap screws that connect the motor to the mounting ring and pull motor away.
3. Replace motor with standard Nema 56J jet pump motor by positioning motor against the mounting frame and assembling with four (4) cap screws.

IMPORTANT: Because damage to the shaft seal can occur in disassembly, a new seal will be necessary.

PUMP REASSEMBLY

Before reassembling the pump, carefully inspect the component parts of the cartridge (stage) assembly, looking for damage, wear or heat distortion. Pay careful attention to spacing direction of components, and location of shims. Refer to Figure 11 for proper facing and parts arrangement. If damage to Stage components is evident, a complete cartridge assembly or individual stage assemblies are available for replacement (See Replacement Parts List).

1. Reassembly should follow the reverse order of the disassembly procedure with special care given to replacement of the rotary seal.
2. Check top and bottom of o-rings for damage. It is recommended that new o-rings be used.
3. Do not use pipe compound or Teflon tape on barrel threads. The o-rings will prevent pump from leaking.
4. After pump is reassembled, tighten the discharge head to a torque of 45-50 ft/lbs. If torque wrench is not available, tighten firmly but avoid distortion or damage to plastic internal parts.
5. After reassembly, apply power momentarily to unit (15 to 30 seconds, using the over ride switch in control box. See Figure 6). The pump and motor should rotate freely or with a light rubbing.

INTERNAL PARTS DETAIL

Figure 11 - Cartridge Assembly Includes Discharge Bearing, Shaft & Coupling Assembly, Diffuser Plate, Impellers, Diffuser Bearings and Diffusers

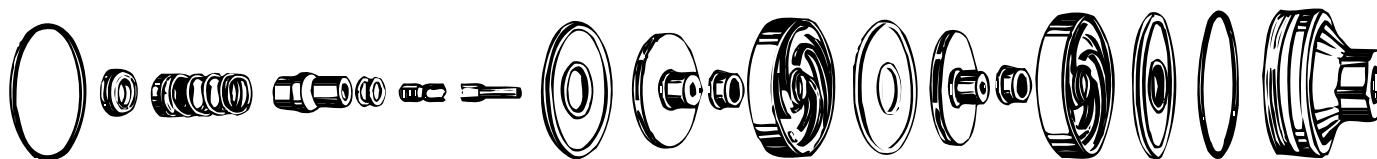

IL0308

NOTE: Illustration shows only two stages. Pump has multiple stages. Individual parts are not available separately.

STAINLESS STEEL PRESSURE BOOSTER PUMP REPAIR PARTS

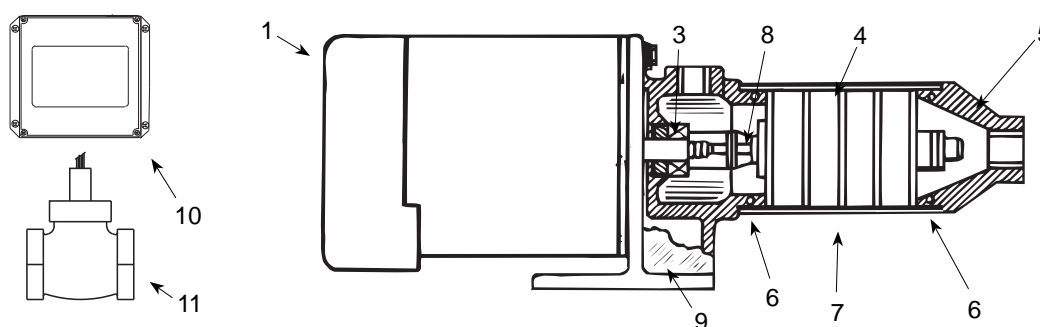

The accompanying parts list is provided for ordering service parts. Please have pump model number and date code ready for immediate service. To ensure proper operation, all repair and service should be performed by a Zoeller Pump Company authorized service station. To order parts call 1-800-928-7867.

ITEM	HORSEPOWER		1/2	3/4
	MODEL NO.		353-0005 353-0006	354-0005 354-0006
	DESCRIPTION	QTY.	PART NO.	
1	Motor, 1 PH Nema J	1	96S105	96S107
	Motor Access Cover	1	021301R	021301R
•	Screws, Access Cover	2	021301	021301
3	Seal, Rotary w/Spring - Viton	1	136682	136682
4	Barrel	1	021458	021495
5	Discharge Head - Stainless Steel	1	139166	139166
6	O-Ring, Viton	2	136607	136607
7	Cartridge Assembly	1	021536†	021537†
8	Shaft & Coupling Assembly	1	021455	021456
9	Mounting Ring - Stainless Steel	1	139100	021592
•	Hex Hd. Cap Screws 3/8 x 3/4"	4	*	*
10	Control Box	1	021948	021948
11	Flow Sensor	1	021946	021946

(*) Standard hardware item
 (•) Not shown
 (†) Cartridge assembly includes: Impeller, Diffusers, Shaft and Coupling Assembly. Components not available individually. Sold as assembly only.