

"QUALITY PUMPS SINCE 1939"

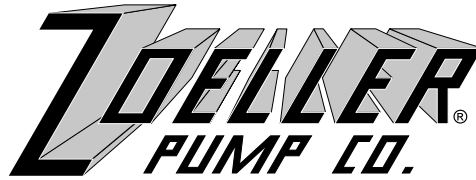

FM2460
0909
Supersedes
1007

Product information presented here reflects conditions at time of publication. Consult factory regarding discrepancies or inconsistencies.

MAIL TO: P.O. BOX 16347 • Louisville, KY 40256-0347
SHIP TO: 3649 Cane Run Road • Louisville, KY 40211-1961
(502) 778-2731 • 1 (800) 928-PUMP • FAX (502) 774-3624



visit our web site:
www.zoeller.com

Patent Pending

MODEL NO. _____
DATE CODE: _____
DATE INSTALLED: _____

**QWIK JON® ULTIMA 204 SYSTEMS
INSTALLATION INSTRUCTIONS
PREINSTALLATION CHECKLIST**

1. Inspect all materials. Occasionally, products are damaged during shipment. If the unit is damaged, contact your dealer before using. **Do Not** remove the test plugs from the pump.
2. Carefully read all the literature provided to familiarize yourself with specific details regarding installation and use before attempting the installation. These materials should be retained for future reference.

 <p>WARNING</p> <p>SEE BELOW FOR LIST OF WARNINGS</p>	 <p>CAUTION</p> <p>SEE BELOW FOR LIST OF CAUTIONS</p>
<ol style="list-style-type: none"> 1. To help reduce the risk of electrical shock, a properly grounded receptacle or control box of grounding type must be installed and protected by a ground fault circuit interrupter (GFCI) in accordance with the National Electrical Code and applicable local codes. Never remove ground pin from plug. If pump is wired direct, a GFCI must be installed in the control box. (SEE WARNING BELOW) 2. Make certain that the ground fault interrupter protected receptacle or control box is within reach of the pump's power supply cord. DO NOT USE AN EXTENSION CORD. Extension cords that are too long or too light do not deliver sufficient voltage to the pump motor. But more important, they could present a safety hazard if the insulation were to become damaged or the connection end were to fall into a damp or wet area. 3. Make sure the pump's electrical supply circuit is equipped with fuses or circuit breakers of proper capacity. A separate branch circuit, sized according to the National Electrical Code for the current shown on the pump name plate is recommended. (See Note 3.) 4. TESTING FOR GROUND. As a safety measure, each electrical outlet should be checked for ground using an Underwriters Laboratory Listed circuit analyzer which will indicate if the power, neutral and ground wires are correctly connected to your outlet. If they are not, call a qualified licensed electrician. 5. FOR YOUR PROTECTION ALWAYS DISCONNECT PUMP FROM ITS POWER SOURCE BEFORE HANDLING. If pump is wired direct, de-energize the circuit at the control box. Grounded pumps are supplied with a 3-prong grounded plug to help protect you against the possibility of electrical shock. DO NOT UNDER ANY CIRCUMSTANCES REMOVE THE GROUND PIN. To reduce the risk of electrical shock, a properly grounded receptacle or control box of grounding type must be installed and protected by a ground fault circuit interrupter (GFCI) in accordance with National Electrical Code and applicable local codes. 6. Installation and checking of electrical circuits and hardware should only be performed by a qualified licensed electrician. 7. According to the state of California (Prop 65), this product contains chemicals known to the state of California to cause cancer and birth defects or other reproductive harm. 	<ol style="list-style-type: none"> 1. Check to be sure your power source is adequate to handle the amperage requirements of the motor as indicated on the pump or unit I.D. tag. 2. All plumbing (discharge and vent lines) must be installed to meet local codes. Unit must be vented. Do not use an automatic plumbing vent device. 3. Maximum operating temperature for model 204 must not exceed 104°F (40°C). Duty cycle should not exceed 30 seconds on/30 seconds off. 4. Do not use cleaning products containing bleach in the attached fixtures as they will degrade the pump seals.
 <p>NOTES</p> <p>SEE BELOW FOR LIST OF NOTES</p>	
<ol style="list-style-type: none"> 1. Repair and service should be performed by an Authorized Service Station only. (Consult Factory.) 2. NOTE: Recommended for installations up to 20' total dynamic head. Consult Factory if installation is above 15' vertical height in 1" pipe. Mini-Grinder Pump is designed for use in Qwik Jon® Ultima units only. It is not designed for use in any other application. 3. Mini-grinder pump is rated for 115V, 60 Hz, 7 Amps, .5 HP. 4. NOTE: Pumps with the "UL" mark and pumps with the "US" mark are tested to UL Standard UL778. CSA Certified pumps are certified to CSA Standard C22.2 No. 108. Qwik Jon® Ultima units only. It is not designed for use in any other application. 5. All fixtures connecting to the system must be on the same floor level. 	
<p>REFER TO WARRANTY ON PAGE 2.</p>	

Limited Warranty

Manufacturer warrants, to the purchaser and subsequent owner during the warranty period, every new product to be free from defects in material and workmanship under normal use and service, when properly used and maintained, for a period of one year from date of purchase by the end user, or 18 months from date of original manufacture of the product, whichever comes first. Parts that fail within the warranty period, one year from date of purchase by the end user, or 18 months from the date of original manufacture of the product, whichever comes first, that inspections determine to be defective in material or workmanship, will be repaired, replaced or remanufactured at Manufacturer's option, provided however, that by so doing we will not be obligated to replace an entire assembly, the entire mechanism or the complete unit. No allowance will be made for shipping charges, damages, labor or other charges that may occur due to product failure, repair or replacement.

This warranty does not apply to and there shall be no warranty for any material or product that has been disassembled without prior approval of Manufacturer, subjected to misuse, misapplication, neglect, alteration, accident or act of God; that has not been installed, operated or maintained in accordance with Manufacturer's installation instructions; that has been exposed to outside substances including but not limited to the following: sand, gravel, cement, mud, tar, hydrocarbons, hydrocarbon derivatives (oil, gasoline, solvents, etc.), or other abrasive or corrosive substances, wash towels or feminine sanitary products,

etc. in all pumping applications. The warranty set out in the paragraph above is in lieu of all other warranties expressed or implied; and we do not authorize any representative or other person to assume for us any other liability in connection with our products.

Contact Manufacturer at, 3649 Cane Run Road, Louisville, Kentucky 40211, Attention: Customer Service Department to obtain any needed repair or replacement of part(s) or additional information pertaining to our warranty.

MANUFACTURER EXPRESSLY DISCLAIMS LIABILITY FOR SPECIAL, CONSEQUENTIAL OR INCIDENTAL DAMAGES OR BREACH OF EXPRESSED OR IMPLIED WARRANTY; AND ANY IMPLIED WARRANTY OF FITNESS FOR A PARTICULAR PURPOSE AND OF MERCHANTABILITY SHALL BE LIMITED TO THE DURATION OF THE EXPRESSED WARRANTY.

Some states do not allow limitations on the duration of an implied warranty, so the above limitation may not apply to you. Some states do not allow the exclusion or limitation of incidental or consequential damages, so the above limitation or exclusion may not apply to you.

This warranty gives you specific legal rights and you may also have other rights which vary from state to state.

Helpful Hints For Easy Installation

1. Read all instructions before beginning installation.
2. Be sure the floor is level within 1/8".
3. Use soapy water to lubricate all seals to aid installation.
4. Install rubber coupling/union in vent line to aid disassembly.
5. Do not use an automatic plumbing vent device.
6. Obtain model number and date code, and record information in the space provided on the front of this manual. Refer to this information when calling Factory.

Do's And Don't's For Installing A Unit

1. DO read all installation material with the unit.
2. DO inspect unit for any visible damage caused by shipping. Contact dealer if unit appears to be damaged.
3. DO clean all visible debris from the unit.
4. DO always disconnect pump from power source before handling. DO always connect to a separately protected and properly grounded ground fault protected circuit. DO NOT ever cut, splice or damage power cord. DO NOT carry or lift pump by its power cord. DO NOT use an extension cord.
5. DO install a ball or gate valve and a union in the discharge line downstream of the check valve.
6. DO test pump immediately after installation to be sure that the system is working properly.
7. DO review all applicable local and national codes and verify that the installation conforms to each of them.
8. We DO NOT recommend this product be connected to utilities other than those found in a normal bathroom application. Washing machines and dishwashers are examples of equipment that we Do Not recommend.
9. DO inspect and test system for proper operations at least every 3 months.

Typical Piping Configurations

NOTE: All installations must comply with all applicable Electrical and Plumbing Codes, including, but not limited, to National Electrical Code; Local; Regional and/or State Plumbing Codes, etc.

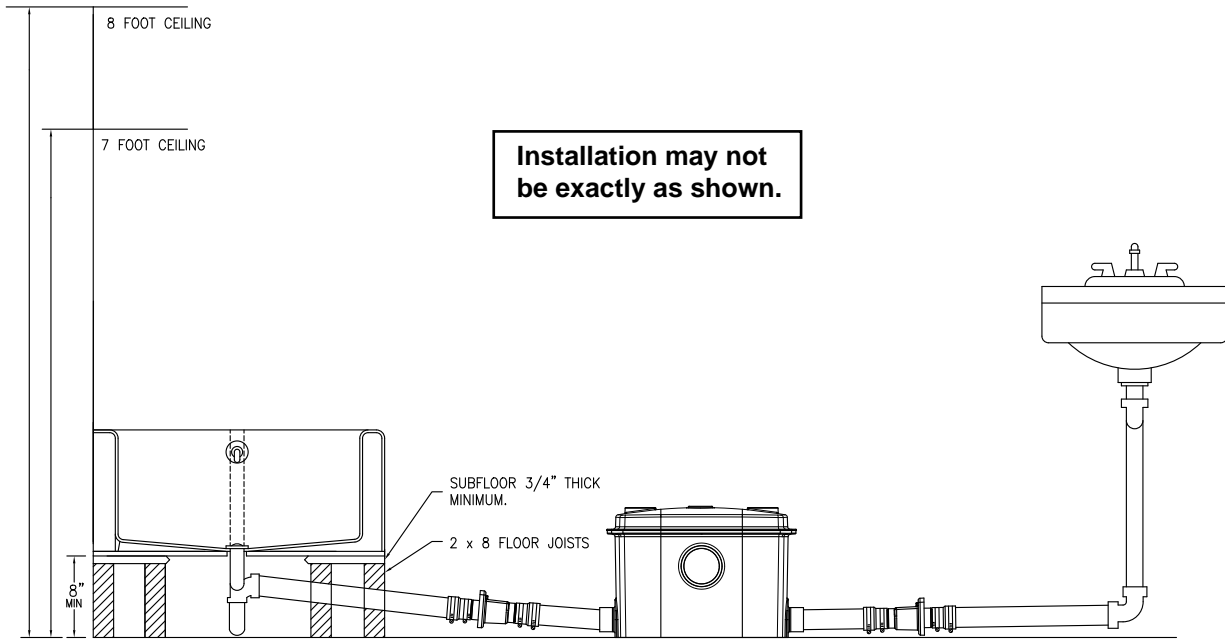

SK2587

Service Parts

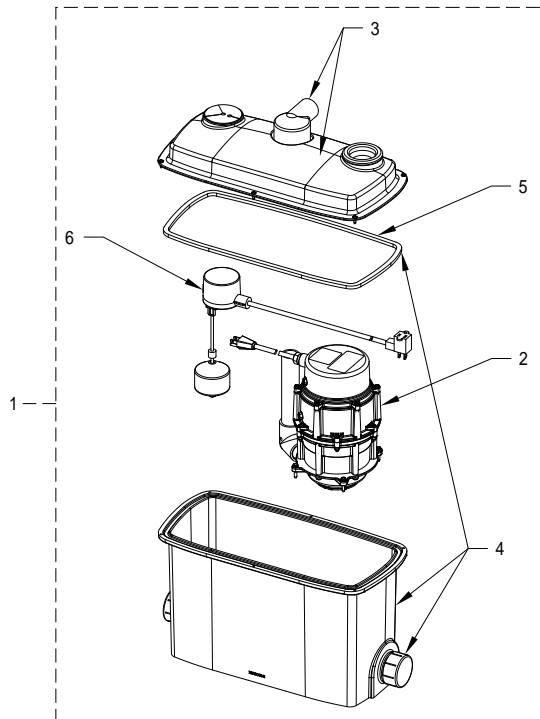

SK2671

Item	Description	Part No.
1	Qwik Jon® Ultima Model 204 System	204-1000
2	N202 replacement pump with discharge pipe	017374
3	Tank cover with discharge fitting	018533
4	Tank	018534
5	Seal	017350
6	Float switch assembly	018532

CONDITION	POSSIBLE CAUSE	REMEDY
A. PUMP WILL NOT START OR RUN.	Low voltage, blown fuse, open circuit.	Have a qualified electrician check fuse and circuit.
	Impeller bound.	Contact a Zoeller Service Station.
	Motor or wiring shorted.	
	Debris on float switch.	Remove debris
B. PUMP STARTS TOO SOON.	Float "ON" point is adjusted too low.	Raise the float stops, make sure the float is between the two stops.
C. WATER LEVEL EXCESSIVE BEFORE PUMP TURNS ON.	Float "ON" point adjusted to high.	Lower the upper float stop.
D. PUMP WILL NOT SHUT OFF OR RUNS TOO LONG BEFORE WATER IS PUMPED.	Pump not plugged into piggyback float switch receptacle.	Ensure pump is not plugged directly into the outlet. Plug pump into piggyback float switch receptacle.
	Debris under float.	Remove debris from around float.
	Faulty float switch.	Contact a Zoeller Service Station.
	Float "Off" point adjusted too low.	Raise the lower float stop.
	Pump is air locked.	Make sure vent hole in discharge pipe is clear.
	Water level too low.	Raise the lower float stop.
E. PUMP OPERATES BUT DELIVERS LITTLE OR NO WATER.	Debris around intake.	Clean area around intake.
	Blockage in discharge pipe.	Remove pipe and flush out debris.
	Low or incorrect voltage.	Have a qualified electrician check house wiring.
	Damaged Impeller.	Contact a Zoeller Service Station.
	Incorrect float adjustment.	Contact Technical Service Department.
	Pump is air locked.	Make sure vent hole in discharge pipe is clear.
	Vertical lift too high.	Change discharge piping or contact Technical Service Department.



▲ WARNING Before servicing a pump, always shut off the main power breaker and then unplug the pump - making sure you are wearing insulated protective sole shoes and not standing in water. Under flooded conditions, contact your local electric company or a qualified licensed electrician for disconnecting electrical service prior to pump removal.

▲ WARNING Submersible pumps contain oil which become pressured and hot under operating conditions - **allow 2½ hours after disconnecting before attempting service.**

If the above checklist does not solve the problem, consult Zoeller Technical Service Department 1-(800) 928-PUMP - **Do not** attempt to service or otherwise disassemble pump.

CARE OF FINISH: Soap and water is all that is recommended for cleaning the outside of the tank. Other cleaning products may cause discoloration and scratching.

Qwik Jon® Ultima Qwik Reference Guide

STEP 1

Location Selection

Plan your new installation carefully.

Floor: The floor should be structurally sound and level within 1/8". If the floor is not level, use hydraulic cement or similar material to level the floor.

Water: A water supply will be needed to operate the shower and lav.

Electrical: A 115 volt GFCI receptacle will be needed to supply electrical power to the pump.

Sewage: Access to a sewage line is required. The Qwik Jon® Ultima requires a 1" (or 3/4" if your codes permit) sewage discharge line to connect to an existing sewage line. A ball or gate valve should be installed in the discharge line.

Vent: Access to a vent pipe is required. The use of a mechanical vent system is NOT recommended.

NOTE: If a built-in installation is to be used, locate the pump unit in an area that will allow access to the pump and switch.

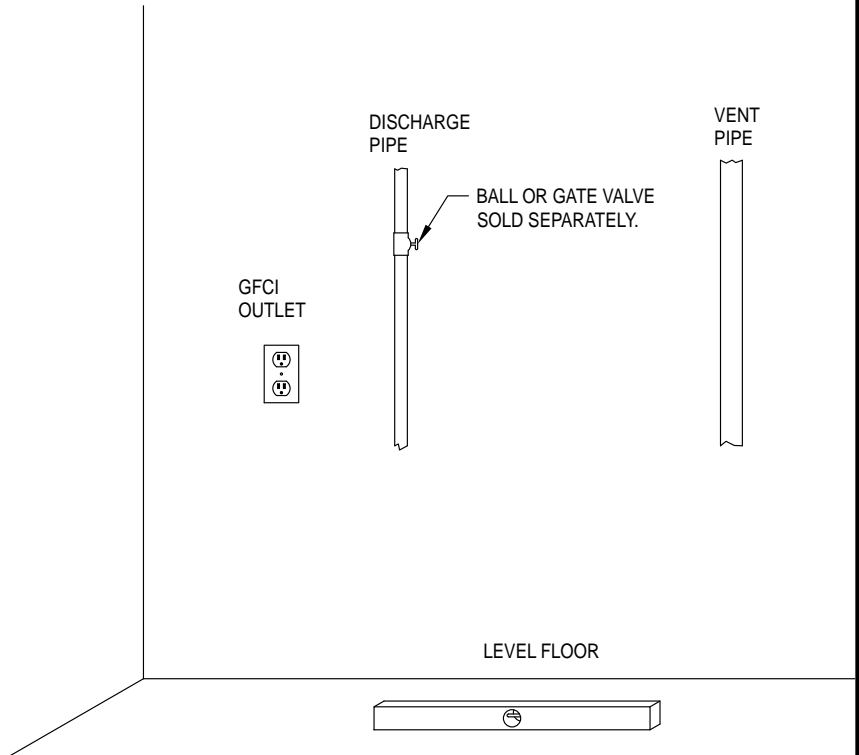

SK2672

STEP 2

Leveling of Pump Unit

CAUTION Do not use wooden shims to level the pump unit!

CAUTION Ensure that nails, screws or other sharp objects do not puncture the pump unit!

Level the pump unit to within 1/8" using hydraulic cement or similar material.

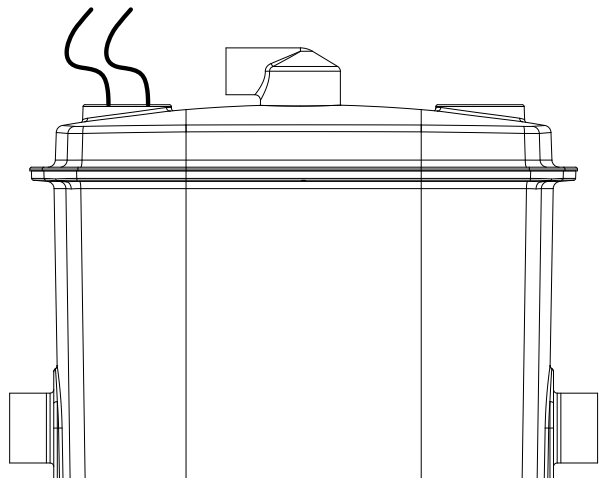

SK2673

STEP 3

Piping

- 1) Adding bathroom fixtures - The Qwik Jon® Ultima is designed to accept bathroom fixtures utilizing the two side inlets. These inlets can be attached via the 2" MPT (outside diameter) or the 1½" slip (inside diameter). These inlets must have the inner portion drilled out using a 1¾" hole saw (see Figure 3.2). This is to ensure there is no leakage problems from inlets not in use. When utilizing side inlets, install a check valve on the incoming line.
- 2) Cut and dry-fit the pipe and fittings as required for 1" diameter discharge pipe (may be reduced to ¾" diameter if codes permit).
- 3) While dry-fitting the discharge pipe, position and mark the location of the pump unit discharge fitting.
- 4) Cut and dry-fit 1-1/2" vent pipe as required to ensure that the vent pipe does not interfere with other components. Make the connection to the pump unit with the provided street elbow. A 2" x 1" 90° discharge fitting has been provided, however, it may be easier to pipe straight up depending on the installation.
CAUTION Proper venting is required. Do not use a mechanical type vent.
- 5) Clean, prime and solvent weld the inlet and discharge piping and pump unit discharge fitting.
CAUTION When applying solvent weld to discharge fitting, ensure that none gets into the check valve assembly (see Figure 5.3). Pay close attention to the proper alignment of the discharge fitting previously marked above.
- 6) Clean and solvent weld vent piping as required for proper venting.

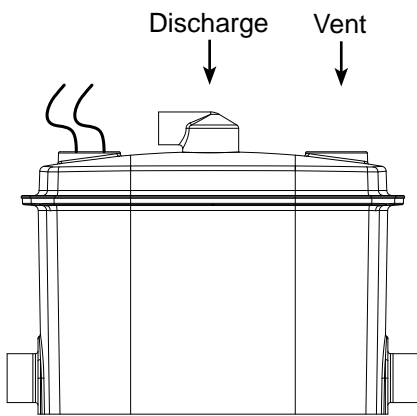

Figure 3.1

SK2673

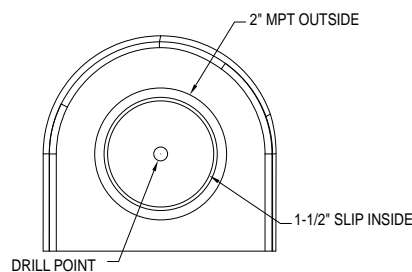

Figure 3.2

SK2586

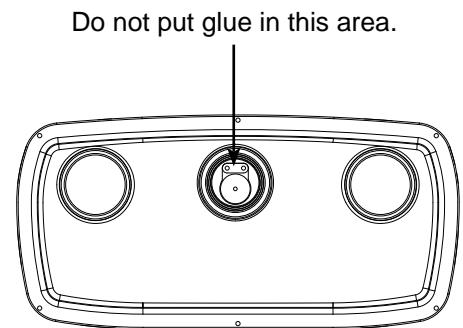

Figure 3.3

SKxxxx

NOTES



www.zoeller.com

ZOELLER
PUMP CO.

MAIL TO: P.O. BOX 16347
Louisville, KY 40256-0347
SHIP TO: 3649 Cane Run Road
Louisville, KY 40211-1961
(502) 778-2731 • 1 (800) 928-PUMP
FAX (502) 774-3624

Manufacturers of..

"QUALITY PUMPS SINCE 1939"