

Notice to Installer: Instructions must remain with installation.

"QUALITY PUMPS SINCE 1939"

Product information presented here reflects conditions at time of publication. Consult factory regarding discrepancies or inconsistencies.

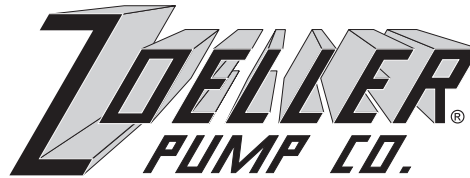

SECTION: 6.10.018
FM2127
0105
Supersedes
1103

MAIL TO: P.O. BOX 16347 • Louisville, KY 40256-0347
SHIP TO: 3649 Cane Run Road • Louisville, KY 40211-1961
(502) 778-2731 • 1 (800) 928-PUMP • FAX (502) 774-3624

visit our web site:
www.zoeller.com

Portable Utility Pump Model 314

INSTALLATION INSTRUCTIONS

These installation instructions are applicable for Model 314 Portable Utility Pump Only





PREINSTALLATION CHECKLIST - ALL INSTALLATIONS

ATTENTION: READ CAREFULLY BEFORE ATTEMPTING TO INSTALL OR OPERATE YOUR PUMP. PROTECT YOURSELF AND OTHERS BY OBSERVING ALL SAFETY INFORMATION AND ADDITIONAL INSTRUCTIONS INCLUDED WITH EQUIPMENT. FAILURE TO COMPLY WITH INSTRUCTIONS COULD RESULT IN PERSONAL INJURY AND/OR PROPERTY DAMAGE! RETAIN FOR FUTURE REFERENCE.



WARNING

SEE BELOW FOR LIST OF WARNINGS

1. **Make sure that the pump is plugged into a properly grounded electrical receptacle.** Use an Underwriters Laboratory listed circuit analyzer to test for proper installation of the circuit and ground. Any service to circuits or receptacles should be conducted by a qualified licensed electrician.
2. **Do not remove the ground pin from the plug under any circumstances.** If the ground pin is damaged, replace the power cord or plug before use.
3. All electrical installations must conform to the requirements of the National Electric Code and all local codes.
4. It is strongly recommended that the unit be plugged into a GFCI protected circuit.
5. **Disconnect power before servicing the pump or motor by unplugging the unit from the outlet.**
6.  Do not touch the motor when operating and allow the motor to cool before touching.
7. This pump is designed for water only, although it can be used to add propylene glycol antifreeze to radiant heating lines. It has not been evaluated for pumping of chemicals.
8.  Do not use this product to pump flammable or explosive liquids.
9.  Do not use this product in hazardous environments or anywhere a spark could potentially ignite explosive gases.
10. Do not handle this product with wet hands or while standing in water or on a wet or damp surface.
11. Model 314 is supplied with an automatically resetting thermal overload device and can restart without warning.
12. Do not submerge the pump or motor in water.
13. Secure the discharge line before starting the pump. An unsecured hose can whip, possibly causing personal injury or property damage.
14.  Provide a means of pressure relief if the pump discharge can be shut off or obstructed. Pumps operating against a closed discharge can create very hot pumped liquid, which can cause burns.
15. Do not operate this product while unattended.
16. Product is portable, and not intended to be permanently installed outdoors. If installed outdoors, care should be taken to protect the unit from rain and other elements of the weather.
17. According to the state of California (Prop 65), this product contains chemicals known to the state of California to cause cancer and birth defects or other reproductive harm.

CAUTION

SEE BELOW FOR LIST OF CAUTIONS

1. Make certain that the power source conforms to the requirements of the equipment as stated on the product nameplates.
2. Check hoses for weak or worn conditions before use and make certain that all connections are secure.
3. Periodically inspect the pump for damage and perform routine maintenance as required.
4. The maximum temperature of the pumped liquid must not exceed 120°F. The minimum allowable temperature is 40°F.
5. Use a screen or strainer on the inlet to prevent solids from entering the pump.
6. To avoid internal pump damage, pump should not be run for more than five minutes while attempting to prime

REFER TO WARRANTY ON PAGE 2.

LIMITED WARRANTY

Manufacturer warrants, to the purchaser and subsequent owner during the warranty period, every new product to be free from defects in material and workmanship under normal use and service, when properly used and maintained, for a period of one year from date of purchase by the end user, or 18 months from date of original manufacture of the product, whichever comes first. Parts that fail within the warranty period, one year from date of purchase by the end user, or 18 months from the date of original manufacture of the product, whichever comes first, that inspections determine to be defective in material or workmanship, will be repaired, replaced or remanufactured at Manufacturer's option, provided however, that by so doing we will not be obligated to replace an entire assembly, the entire mechanism or the complete unit. No allowance will be made for shipping charges, damages, labor or other charges that may occur due to product failure, repair or replacement.

This warranty does not apply to and there shall be no warranty for any material or product that has been disassembled without prior approval of Manufacturer, subjected to misuse, misapplication, neglect, alteration, accident or act of God; that has not been installed, operated or maintained in accordance with Manufacturer's installation instructions; that has been exposed to outside substances including but not limited to the following: sand, gravel, cement, mud, tar, hydrocarbons, hydrocarbon derivatives (oil, gasoline, solvents, etc.), or other abrasive or corrosive substances, wash towels or feminine sanitary products, etc. in all pump-

ing applications. The warranty set out in the paragraph above is in lieu of all other warranties expressed or implied; and we do not authorize any representative or other person to assume for us any other liability in connection with our products.

Contact Manufacturer at, 3649 Cane Run Road, Louisville, Kentucky 40211, Attention: Customer Service Department to obtain any needed repair or replacement of part(s) or additional information pertaining to our warranty.

MANUFACTURER EXPRESSLY DISCLAIMS LIABILITY FOR SPECIAL, CONSEQUENTIAL OR INCIDENTAL DAMAGES OR BREACH OF EXPRESSED OR IMPLIED WARRANTY; AND ANY IMPLIED WARRANTY OF FITNESS FOR A PARTICULAR PURPOSE AND OF MERCHANTABILITY SHALL BE LIMITED TO THE DURATION OF THE EXPRESSED WARRANTY.

Some states do not allow limitations on the duration of an implied warranty, so the above limitation may not apply to you. Some states do not allow the exclusion or limitation of incidental or consequential damages, so the above limitation or exclusion may not apply to you.

This warranty gives you specific legal rights and you may also have other rights which vary from state to state.

TROUBLE SHOOTING GUIDE



⚠ WARNING

ELECTRICAL PRECAUTIONS- Before servicing a pump, always shut off the main power breaker and then unplug the pump. Make sure you are not standing in water and are wearing insulated protective sole shoes. Under flooded conditions, contact your local electric company or a qualified licensed electrician for disconnecting electrical service prior to pump removal.

TROUBLESHOOTING CHART

A. Pump will not begin pumping or retain prime after operating, or stops pumping water	<ol style="list-style-type: none"> 1. Air leak in inlet line 2. Fittings not tight 3. Hose kinked or looped 4. Inlet hose out of water 5. Clogged inlet 6. Inlet lift too high 7. Impeller blocked 8. Worn seal 	<ol style="list-style-type: none"> 1. Repair or replace inlet line, make sure fittings are air tight, use Teflon® tape if necessary 2. Tighten fittings air tight, use Teflon® tape if necessary 3. Straighten hose 4. Submerge inlet hose end 5. Clean inlet 6. Lower pump 7. Remove blockage 8. Replace seal
B. Pump will not start or run	<ol style="list-style-type: none"> 1. Blown fuse 2. Low line voltage 3. Worn brushes 4. Impeller blocked 5. Defective motor 	<ol style="list-style-type: none"> 1. If blown, replace with proper sized fuse or reset circuit breaker 2. If voltage is under 108 volts, check wiring size 3. Replace brushes 4. Remove blockage 5. Replace pump
C. Flow rate is too low	<ol style="list-style-type: none"> 1. Piping or hose is kinked or damaged 2. Low line voltage 3. Too much discharge hose friction 	<ol style="list-style-type: none"> 1. Clean or replace 2. If voltage is under 108 volts, check wiring size 3. Shorten and/or increase diameter of hose.
D. Seal leaks	<ol style="list-style-type: none"> 1. Worn seal 2. Pump head loose on motor 	<ol style="list-style-type: none"> 1. Replace seal 2. Ensure proper assembly and no obstructions, tighten bolts

DESCRIPTION

This portable utility pump is designed to be used as a transfer pump for such applications as emptying water heaters, swimming pools, livestock tanks, boats, etc. Pump can also be used for an intermittent pressure booster for applications such as washing cars, cleaning driveways, etc. The motor is air cooled. It is **NOT** designed to operate under water.

INSTALLATION

▲ DANGER  Always disconnect power source before attempting to install, service or maintain the pump. Never handle a pump with wet hands or when standing on wet or damp surface or in water. Fatal electrical shock could occur.

1. A ground fault circuit interrupter (GFCI) is recommended.

▲ DANGER  Risk of electrical shock. This pump is supplied with a grounding conductor and grounding type attachment plug. A grounded receptacle in conformance with current NEC and local codes must be used (See Figure 1).

2. This pump operates on 115V, 60Hz AC, single phase.

▲ DANGER  Risk of fatal electrical shock. Never cut off the round grounding prong. Cutting the cord or plug will void the warranty and make the pump inoperable.

3. Figure 2 shows a typical installation. Threaded adapters are furnished for attaching garden hose where conditions permit its use. In no case should the pump be more than 15 feet above or away from inlet source. Use of foot valve on inlet line is recommended.

▲ IMPORTANT Make sure the inlet hose is **NOT** coiled or kinked above or below water level.

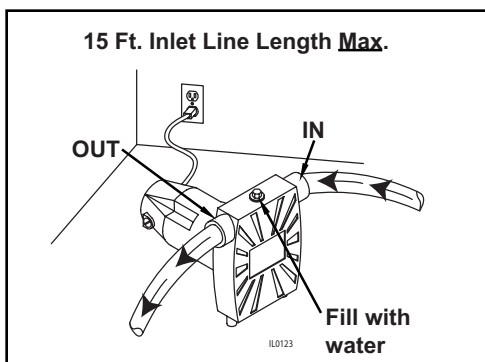

Figure 2

4. The inlet line may be galvanized pipe, plastic pipe, or non-collapsible hose. Small leaks in suction line greatly reduce efficiency of pump and may prevent priming.

▲ IMPORTANT Typical garden hose will collapse under suction conditions and should not be used in the inlet, except for pressure boosting situations.

5. Use a strainer when pumping from a creek, pond, or source where foreign objects may be sucked into the pump.
6. A regular 3/4" garden hose may be used as a discharge line. Keep the total length as short as possible to prevent excessive friction loss.

OPERATION

▲ IMPORTANT Pump must be filled with water before operation. Running the pump dry or pumping any sand or other abrasives will cause damage to the shaft seal or impeller and void the warranty.

1. **▲ DANGER**  Product is portable, and not intended to be permanently installed outdoors. If installed outdoors, care should be taken to protect the unit from rain and other elements of the weather. This unit is not waterproof or weatherproof and is not intended to be used in showers, saunas, or other potentially wet locations. The motor is designed to be used in a clean, dry location with access to adequate cooling air. Ambient temperature around the motor should not exceed 104°F (40°C).

2. Remove priming plug and fill with water. Reinstall plug.

▲ IMPORTANT To help with the priming of the pump, a foot valve can be installed on the suction line. The use of a foot valve is strongly recommended to be installed on inlet lines lifting over five feet.

3. Plug power cord into GFCI protected electrical outlet. The pump will prime in a few minutes, depending on inlet line length.

▲ IMPORTANT To avoid internal pump damage, if after five minutes the pump has not begun pumping water, turn off the pump, remove the priming plug, re-fill pump with water, reinstall priming plug and plug pump back in.

4. In the case of pressure boosting, turn water on before starting pump. This force primes the pump. Then, plug power cord into GFCI protected electrical outlet.
5. Unplug cord to turn unit off.

MAINTENANCE

▲ WARNING Let pump cool for at least 20 minutes before attempting to service. Motor may be extremely hot. Personal injury may result.

1. Pump should be checked periodically for proper operation.

▲ DANGER  Always disconnect the electrical supply before attempting to install, service, or perform any maintenance. If the power source is out of sight, lock and tag in the open (off) position to prevent unexpected power applications. Disconnect electrical cord from power supply. Failure to do so could result in fatal electrical shock. Only qualified electricians should repair this unit. Improper repair could result in fatal electrical shock.

BRUSH REPLACEMENT

▲ IMPORTANT Brushes for this pump should be inspected after every 100 hours of operation.

Pumps with excess of 100 hours of operation may stop operating or fail to start. This could be due to worn brushes or carbon build-up. The brushes should be removed and carbon removed. Worn brushes are not covered under warranty.

1. Disconnect electrical cord from power supply.
2. Remove brush caps with screwdriver.
3. Remove old brush assembly.
4. Insert new brush assembly.
5. Replace brush caps.

For other problems, consult troubleshooting chart.

SPECIFICATIONS

Motor 1/2 HP Single Phase, 115V, 60Hz, 8,000 RPM
 Series Wound (brush type) AC operation

Maximum Fluid Temperature 120°F
 Inlet/Outlet Openings 3/4" NPT

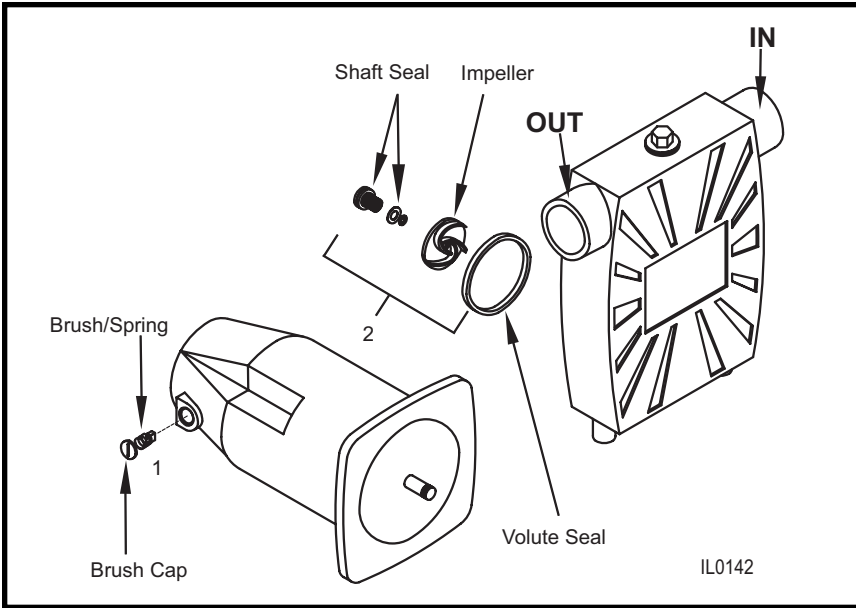

REPLACEMENT PARTS LIST			
Ref. No.	Description	Part Number	Req'd Quantity
1	Brush Kit*	015846	1
2	Impeller and Seal Kit	015847	1

*Kit includes one pair of brushes.

PERFORMANCE

**"High Capacity" Water Mover
 Pump Performance Curve**

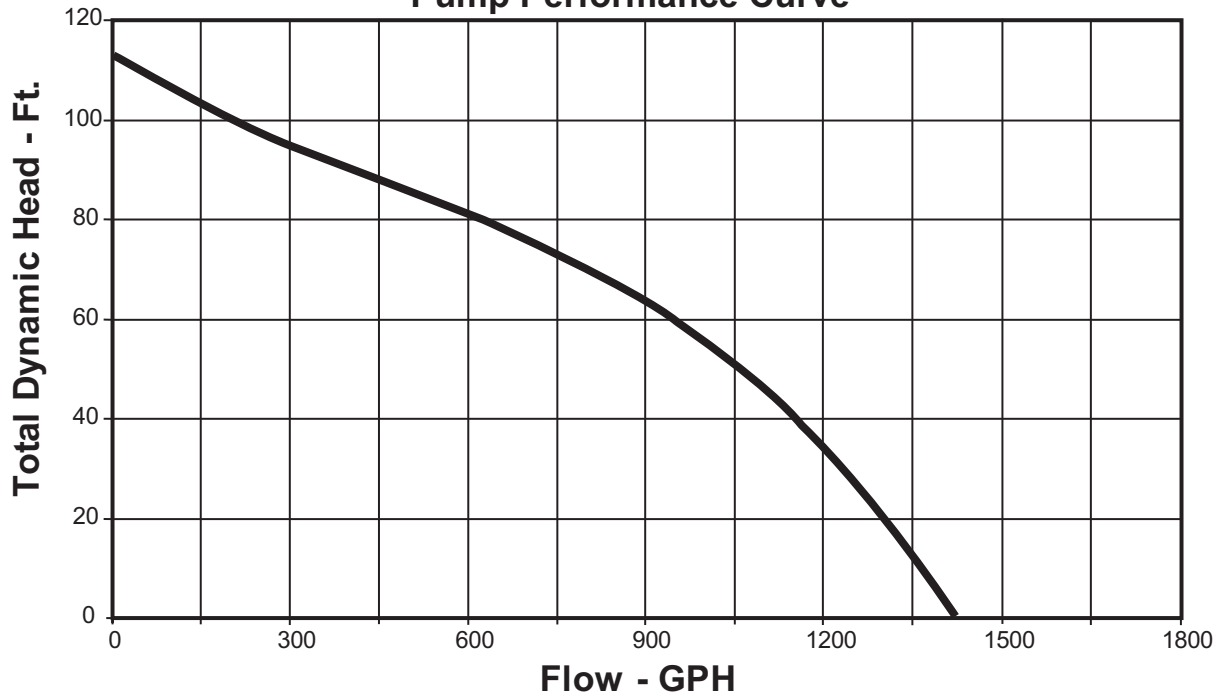

IL0153