

“QUALITY PUMPS SINCE 1939”

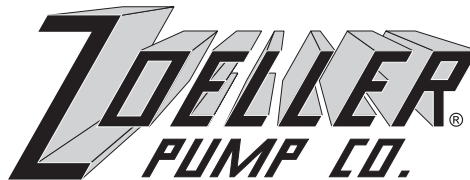

FM2092

0207/2

Supersedes

0207

Product information presented here reflects conditions at time of publication. Consult factory regarding discrepancies or inconsistencies.

MAIL TO: P.O. BOX 16347 • Louisville, KY 40256-0347
SHIP TO: 3649 Cane Run Road • Louisville, KY 40211-1961
(502) 778-2731 • 1 (800) 928-PUMP • FAX (502) 774-3624

visit our web site: www.zoeller.com

“MIGHTY MOVER”

INSTALLATION INSTRUCTIONS

These installation instructions are applicable for Models 310 and 311 Portable Utility Pump

PREINSTALLATION CHECKLIST - ALL INSTALLATIONS

ATTENTION: READ CAREFULLY BEFORE ATTEMPTING TO INSTALL OR OPERATE YOUR PUMP. PROTECT YOURSELF AND OTHERS BY OBSERVING ALL SAFETY INFORMATION AND ADDITIONAL INSTRUCTIONS INCLUDED WITH EQUIPMENT. FAILURE TO COMPLY WITH INSTRUCTIONS COULD RESULT IN PERSONAL INJURY AND/OR PROPERTY DAMAGE! RETAIN FOR FUTURE REFERENCE.



WARNING

SEE BELOW FOR LIST OF WARNINGS

- 1. Make sure that the pump is plugged into a properly grounded electrical receptacle. Use an Underwriters Laboratory listed circuit analyzer to test for proper installation of the circuit and ground. Any service to circuits or receptacles should be conducted by a qualified licensed electrician.
2. Do not remove the ground pin from the plug under any circumstances. If the ground pin is damaged, replace the power cord or plug before use.
3. All electrical installations must conform to the requirements of the National Electrical Code and all local codes.
4. It is strongly recommended that the 115 volt unit (model 311) be plugged into a G.F.C.I. protected circuit.
5. Disconnect power before servicing the pump or motor. For the model 310, remove both battery clips from the battery. For the model 311, unplug the unit from the outlet.
6. Do not touch the motor when operating and allow the motor to cool before touching it afterwards.
7. This pump is designed for water without solids only. It has not been evaluated for pumping of chemicals.
8. Do not use this product to pump flammable or explosive liquids.
9. Do not use this product in hazardous environments or anywhere a spark could potentially ignite explosive gases.
10. Do not handle this product with wet hands or while standing in water or on a wet or damp surface.
11. The model 311 is supplied with an automatically resetting thermal overload device and can restart without warning.
12. Do not submerge the pump or motor in water.
13. Secure the discharge line before starting the pump. An unsecured hose can whip, possibly causing personal injury or property damage.
14. Provide a means of pressure relief if the pump discharge can be shut off or obstructed. Pumps operating against a closed discharge can create very hot pumped liquid, which can cause burns.
15. Do not operate this product while unattended. Do not run dry.
16. Risk of electric shock - These pumps have not been investigated for use in swimming pool areas.

CAUTION

SEE BELOW FOR LIST OF CAUTIONS

- 1. Make certain that the power source conforms to the requirements of the equipment as stated on the product nameplates.
2. Check hoses for weak or worn conditions before use and make certain that all connections are secure.
3. Periodically inspect the pump for damage and perform routine maintenance as required.
4. The maximum temperature of the pumped liquid must not exceed 130 deg. F. The minimum allowable temperature is 40 deg. F.
5. Use a screen or strainer on the inlet to prevent solids from entering the pump.
6. NOTE: Pumps with the “UL” mark and pumps with the “US” mark are tested to UL Standard UL778. CSA Certified pumps are certified to CSA Standard C22.2 No. 108.

REFER TO WARRANTY ON PAGE 2.

LIMITED WARRANTY

Manufacturer warrants, to the purchaser and subsequent owner during the warranty period, every new product to be free from defects in material and workmanship under normal use and service, when properly used and maintained, for a period of 90 days from date of purchase by the end user, or 6 months from date of original manufacture of the product, whichever comes first. Parts that fail within the warranty period, 90 days from date of purchase by the end user, or 6 months from the date of original manufacture of the product, whichever comes first, that inspections determine to be defective in material or workmanship, will be repaired, replaced or remanufactured at Manufacturer's option, provided however, that by so doing we will not be obligated to replace an entire assembly, the entire mechanism or the complete unit. No allowance will be made for shipping charges, damages, labor or other charges that may occur due to product failure, repair or replacement.

This warranty does not apply to and there shall be no warranty for any material or product that has been disassembled without prior approval of Manufacturer, subjected to misuse, misapplication, neglect, alteration, accident or act of God; that has not been installed, operated or maintained in accordance with Manufacturer's installation instructions; that has been exposed to outside substances including but not limited to the following: sand, gravel, cement, mud, tar, hydrocarbons, hydrocarbon derivatives (oil, gasoline, solvents, etc.), or other abrasive or corrosive substances, wash towels or feminine sanitary products, etc. in all pump-

ing applications. The warranty set out in the paragraph above is in lieu of all other warranties expressed or implied; and we do not authorize any representative or other person to assume for us any other liability in connection with our products.

Contact Manufacturer at, 3649 Cane Run Road, Louisville, Kentucky 40211, Attention: Customer Service Department to obtain any needed repair or replacement of part(s) or additional information pertaining to our warranty.

MANUFACTURER EXPRESSLY DISCLAIMS LIABILITY FOR SPECIAL, CONSEQUENTIAL OR INCIDENTAL DAMAGES OR BREACH OF EXPRESSED OR IMPLIED WARRANTY; AND ANY IMPLIED WARRANTY OF FITNESS FOR A PARTICULAR PURPOSE AND OF MERCHANTABILITY SHALL BE LIMITED TO THE DURATION OF THE EXPRESSED WARRANTY.

Some states do not allow limitations on the duration of an implied warranty, so the above limitation may not apply to you. Some states do not allow the exclusion or limitation of incidental or consequential damages, so the above limitation or exclusion may not apply to you.

This warranty gives you specific legal rights and you may also have other rights which vary from state to state.

TROUBLE SHOOTING GUIDE



▲ WARNING ELECTRICAL PRECAUTIONS- Before servicing a pump, always shut off the main power breaker and then unplug the pump. Make sure you are not standing in water and are wearing insulated protective sole shoes. Under flooded conditions, contact your local electric company or a qualified licensed electrician for disconnecting electrical service prior to pump removal.

| CONDITION | COMMON CAUSES |
|--|--|
| A. Pump will not prime or retain prime after operating. | Suction lift too high, hose kinked or hose fitting not tight on head, air leak in suction line, defective cam or impeller or gasket leaking. |
| B. Pump runs but no fluid. | Faulty suction piping, defective cam or impeller, suction lift too high, discharge head too great, clogged inlet, pump too far from liquid. |
| C. Motor runs too hot. | Voltage incorrect, excessive discharge pressure, impeller swollen, liquid, too viscous, plugged or kinked discharge, insufficient air flow on motor, liquid too hot. |
| D. Flow rate is low. | Piping or hose is fouled or damaged, clogged impeller, worn impeller, voltage incorrect, hoses too long. |
| E. Pump will not run. | Inspect power source, impeller jammed, motor overheated. |

DESCRIPTION

This utility pump is designed for general commercial and industrial applications. Unit is designed for water, but is not submersible. For use transferring liquids, emptying or filling tanks, sinks or bowls. Self-priming to 7 ft. (311 only) if the impeller is initially wet (primed). Intermittent duty.

NOTE: Unit is NOT RECOMMENDED for use with soap detergents, gasoline, fuel oil, flammable, explosive or combustible liquids or other fluids not compatible with pump component materials. Do not use unit in enclosed areas.

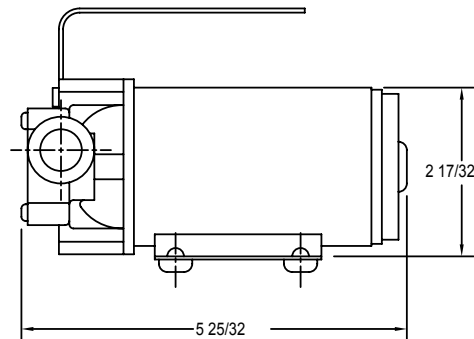
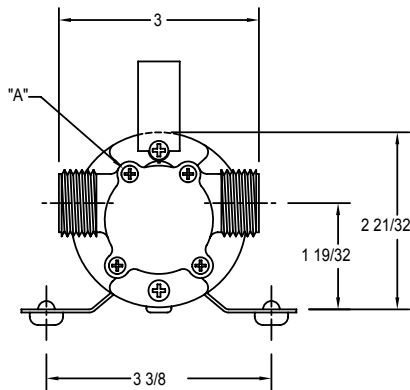

SK2206

INSTALLATION

1. Pump should be placed as close to source of liquid and power as possible, not more than 7 feet above liquid source if self-priming (311 only), and not more than 25 feet from power source.
2. Use reinforced plastic or fabric tubing or metal pipe for the suction side of the pump. This will prevent collapse of the suction piping. Discharge piping should never be larger than suction piping!
3. Attach suction line piping to the suction inlet and discharge line piping to the discharge outlet.
4. Avoid using looped sections of pipe which might permit air to become entrapped.
5. Piping should be checked for any leaks at the connections. Small leaks in suction line greatly reduce efficiency of pump, and may prevent priming. (Never operate a pump unless it is secured to a solid foundation.)
6. Do not operate pump dry. Impeller and seal damage will result.
7. Protect pump from extreme heat, cold, and humidity. This unit is not waterproof and is not intended to be used in showers, saunas, or other potentially wet locations. The motor is designed to be used in a clean, dry location with access to an adequate supply of cooling air. Ambient temperature around the motor should not exceed 104°F (40°C). This unit is not weatherproof, nor is it able to be submersed in water or any other liquid.
8. Install a foot valve and prime pump when suction lift is over six feet or when suction line is longer than six feet.
9. It is strongly recommended that the Model 311 is plugged into a G.F.C.I. (Ground Fault Circuit Interrupter). Consult your local electrician for installation and availability.

OPERATION

1. Model 311 is self-priming and should prime itself within 30 seconds after pump is started. Wetting impeller with pumped fluid and keeping the impeller coated with petroleum jelly will lengthen its life and improve priming action. Running the impeller dry for as short as 30 seconds can ruin the impeller (Ref. No. 5). Keep suction line as short as possible.

NOTE: An easy way to prime the pump (wet impeller), if using a garden hose, is to fill the discharge hose; elevate the discharge hose slightly to retain water and start the pump. Another method would be to disconnect

the discharge hose from the pump, making a U-bend of the discharge hose, fill the hose and then reconnect to the pump (without losing the water). In both cases, the water behind the impeller will seal the pump and it will prime almost immediately.

2. Be sure hose attachments or piping connections are tight. Any leakage in suction side will prevent pump from priming.

MAINTENANCE

1. Always drain pump when not in use.
2. If pump is not going to be used for a month or longer, flush with fresh water and remove body cover, take impeller out, clean inside body and apply generous coating of petroleum jelly to both inside body and impeller before replacing impeller in body.
3. Pump should be checked daily, weekly, monthly, etc. for proper operation. If anything has changed since unit was new, unit should be removed and repaired or replaced. Only qualified electricians or servicemen should attempt to repair the motor of this unit. Improper repair and/or assembly can cause an electrical shock hazard.

HOW TO REPLACE IMPELLER

Replace impeller when it has been worn or damaged by foreign objects, pumping improper liquid or dry running.

1. Remove four screws at "A" (see figure above).
2. Remove cover plate.
3. Using your fingers, remove damaged or worn impeller.
4. Clean the inside of the pump head and remove any foreign materials which will obstruct the impeller's operation.
5. Apply petroleum jelly or similar lubricant to both the inside of pump head and to the outside diameter of the impeller.
6. Align the flat on the inside of the new impeller with the flat on the motor shaft. Push into place while twisting blades in a clockwise direction.
7. Place new gasket on pump body face, align holes and replace cover.
8. Tighten all four screws evenly and snugly.
9. Replacement impeller/gasket kits are available as part number 015391.

PERFORMANCE

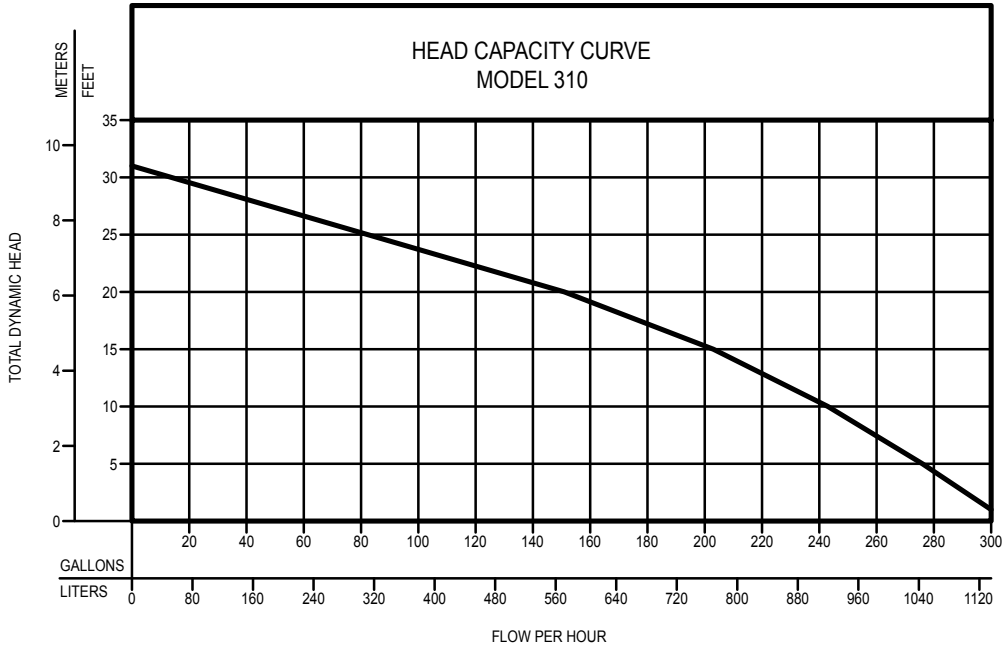

TOTAL DYNAMIC HEAD/CAPACITY
PER HOUR
DEWATERING

| MODEL | | 310 | |
|----------------|--------|---------------|--------|
| Feet | Meters | Gal. | Liters |
| 1 | 0.3 | 300 | 1136 |
| 5 | 1.5 | 276 | 1045 |
| 10 | 3.0 | 243 | 920 |
| 15 | 4.6 | 203 | 768 |
| 20 | 6.1 | 151 | 572 |
| 25 | 7.6 | 82 | 310 |
| Shut-off Head: | | 31 ft. (9.5m) | |

SK2176A

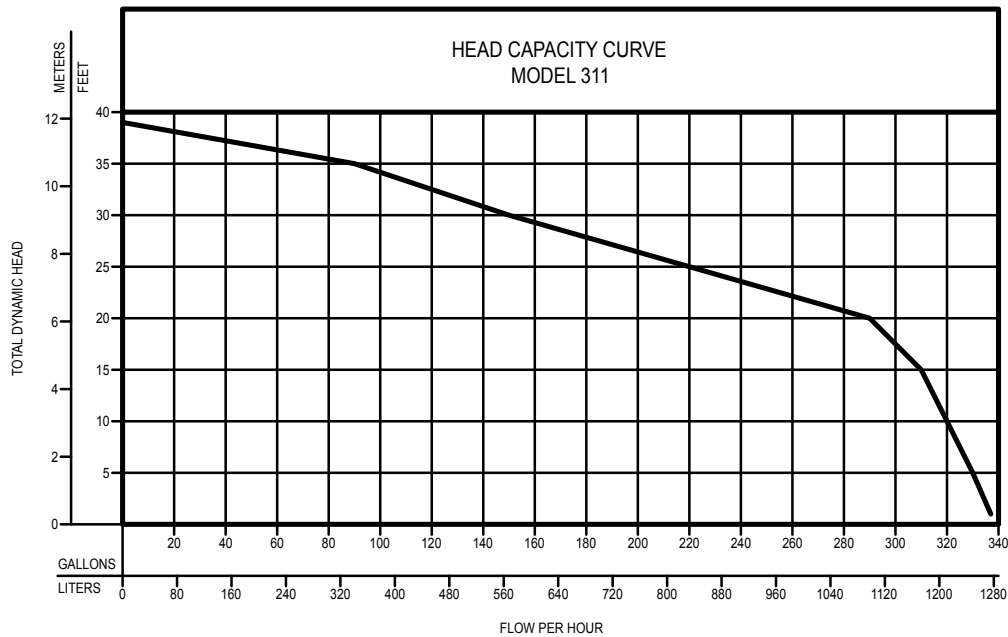

TOTAL DYNAMIC HEAD/CAPACITY
PER HOUR
DEWATERING

| MODEL | | 311 | |
|----------------|--------|----------------|--------|
| Feet | Meters | Gal. | Liters |
| 1 | 0.3 | 337 | 1276 |
| 5 | 1.5 | 330 | 1249 |
| 10 | 3.0 | 320 | 1211 |
| 15 | 4.6 | 310 | 1173 |
| 20 | 6.1 | 290 | 1098 |
| 25 | 7.6 | 220 | 833 |
| 30 | 9.1 | 150 | 568 |
| 35 | 10.7 | 90 | 341 |
| Shut-off Head: | | 39 ft. (11.9m) | |

SK2176B