

## Series 4700 Vertical Multi-Stage Pump

## VMS 03

## SUBMITTAL



JOB: _____	REPRESENTATIVE: _____
ENGINEER: _____	ORDER NO: _____ DATE: _____
CONTRACTOR: _____	SUBMITTED BY: _____ DATE: _____
	APPROVED BY: _____ DATE: _____

PUMP DESIGN DATA			
NO. OF PUMPS:			
TAG:			
CAPACITY:	USgpm (L/s)	HEAD:	ft. (m)
LIQUID:		VISCOSITY:	
TEMPERATURE:		SPECIFIC GRAVITY:	
FLANGE SIZE:	SUCTION - 1.25" (32 mm)	DISCHARGE - 1.25" (32 mm)	
MAXIMUM WORKING TEMPERATURE: 250°F (120°C)			

MOTOR DESIGN DATA			
HP:		RPM:	3600
FRAME SIZE:		ENCLOSURE:	<input type="checkbox"/> ODP <input type="checkbox"/> TEFC
VOLTS:		HERTZ:	60
		PHASE:	<input type="checkbox"/> 1 <input type="checkbox"/> 3
EFFICIENCY: <input type="checkbox"/> ENERGY EFF <input type="checkbox"/> NEMA PREMIUM LEVEL _____ %			

MATERIALS OF CONSTRUCTION	
FLANGE RATING	ANSI 250
PUMP CASING	EN 1.4301 (AISI 304)
IMPELLERS	EN 1.4301 (AISI 304)
STAGE CASING	EN 1.4301 (AISI 304)
DIFFUSERS	EN 1.4301 (AISI 304)
PUMP SHAFT	EN 1.4401 (AISI 316)
JACKET TUBE	EN 1.4301 (AISI 304)
OTHER COMPONENTS	
INTERMEDIATE BEARING	TUNGSTEN CARBIDE
"O" RINGS	FPM
MOTOR PEDESTAL	Cast iron EN-GJL-200-EN 1561
PUMP BASE	Cast iron EN-GJL-200-EN 1561
MECHANICAL SEAL FACES	Silicon carbide/Carbon/FPM

REMARKS

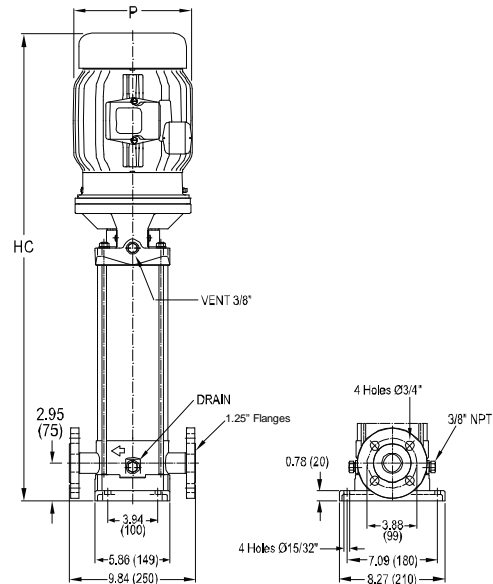

PUMP SIZE	hp	NEMA FRAME	MWP*	DIMENSIONS		WEIGHT lbs. (kg)
				HC	P	
VMS 0302	0.5	56C	232	21.56 (548)	7.25 (184)	57 (26)
VMS 0303	0.75	56C		23.89 (607)	7.25 (184)	60 (27)
VMS 0304	1	56C		25.53 (648)	7.25 (184)	63 (29)
VMS 0305	1.5	143TC		25.90 (658)	8.63 (219)	71 (32)
VMS 0306	1.5	143TC		26.73 (679)	8.63 (219)	74 (34)
VMS 0307	2	145TC		28.09 (714)	8.63 (219)	83 (38)
VMS 0308	2	145TC		28.92 (735)	8.63 (219)	83 (38)
VMS 0309	3	145TC		30.50 (775)	8.63 (219)	89 (40)
VMS 0311	3	145TC		370	32.15 (817)	8.63 (219)
VMS 0312	3	145TC	32.98 (838)		8.63 (219)	90 (41)
VMS 0313	3	145TC	34.20 (869)		8.63 (219)	93 (42)
VMS 0315	5	184TC	39.44 (1002)		10.38 (264)	127 (58)
VMS 0318	5	184TC	41.93 (1065)		10.38 (264)	135 (61)

All dimensions are in inches (mm) and are approximate.

\*Maximum Working Pressure

# ARMSTRONG

## PERFORMANCE CURVES

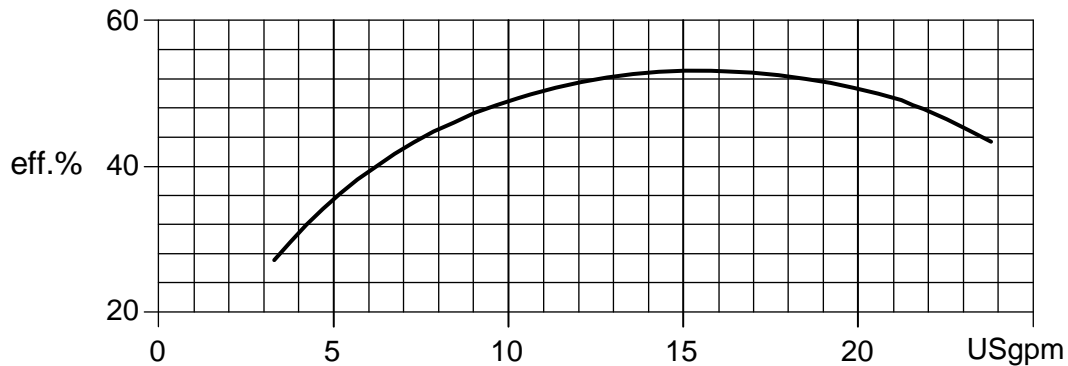
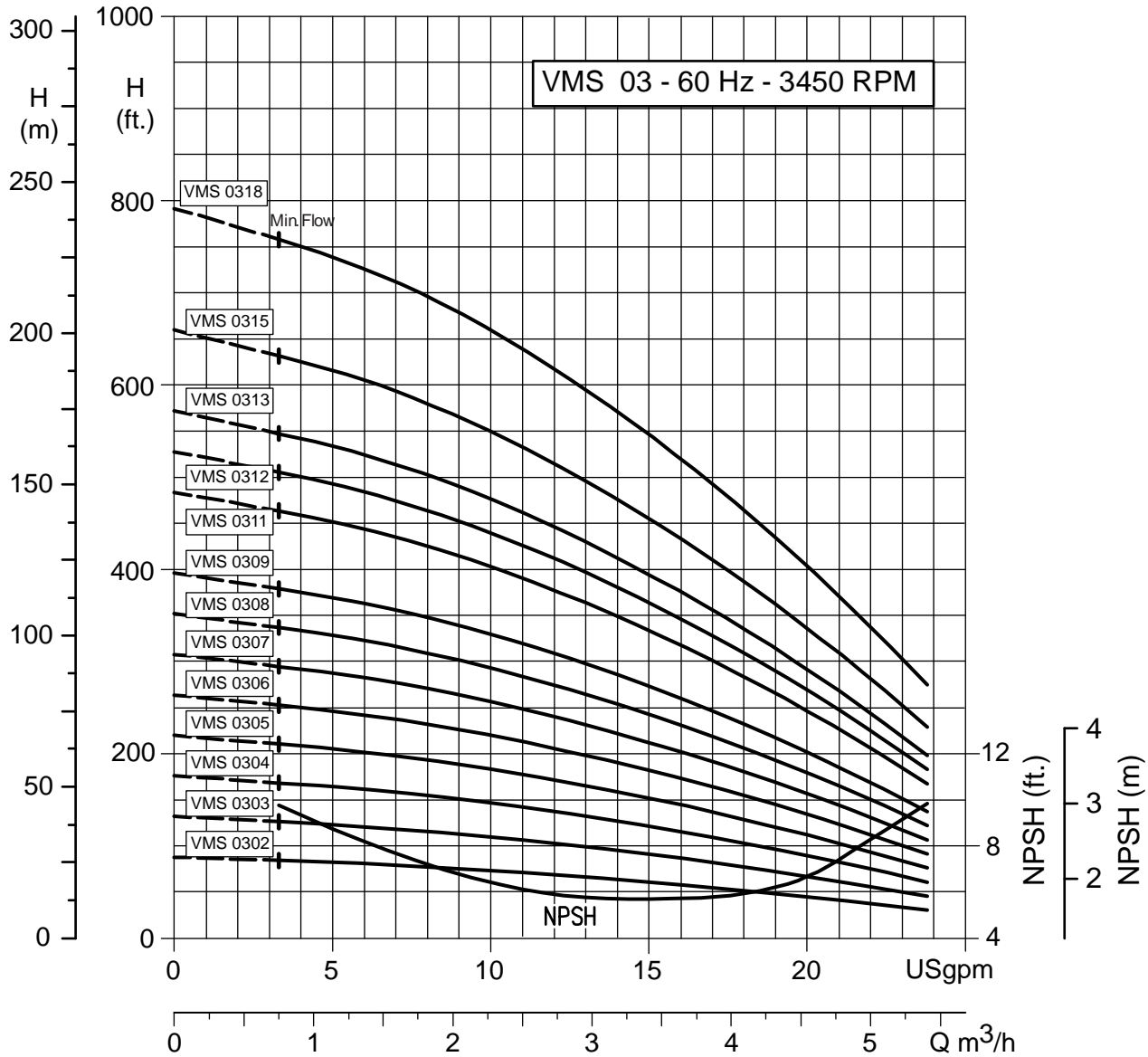

**S. A. Armstrong Limited**  
 23 Bertrand Avenue  
 Toronto, Ontario  
 Canada, M1L 2P3  
 T: (416) 755-2291  
 F (Main): (416) 759-9101

**Armstrong Pumps Inc.**  
 93 East Avenue  
 North Tonawanda, New York  
 U.S.A. 14120-6594  
 T: (716) 693-8813  
 F: (716) 693-8970

**Armstrong Holden Brooke Pullen**  
 Wenlock Way  
 Manchester  
 United Kingdom, M12 5JL  
 T: +44 (0) 161 223 2223  
 F: +44 (0) 161 220 9660



© S.A. Armstrong Limited 2010

For Armstrong locations worldwide, please visit [www.armstrongintegrated.com](http://www.armstrongintegrated.com)