

# ARMSTRONG®

## SERIES 40PF 4 x 3 x 8.5 FM

# ES PUMP

END SUCTION PUMP

FILE NO.:	F40.65
DATE:	July 3, 2002
SUPERSEDES:	NEW
DATE:	NEW

## SUBMITTAL

JOB: _____	REPRESENTATIVE: _____
_____	_____
_____	_____
ENGINEER: _____	ORDER NO: _____ DATE: _____
CONTRACTOR: _____	SUBMITTED BY: _____ DATE: _____
	APPROVED BY: _____ DATE: _____

TAG/REF:								
PUMP DATA	FLOW	HEAD	ENGINE DATA	HP	RPM	BAT. VOLTAGE	TANK SIZE	OTHER

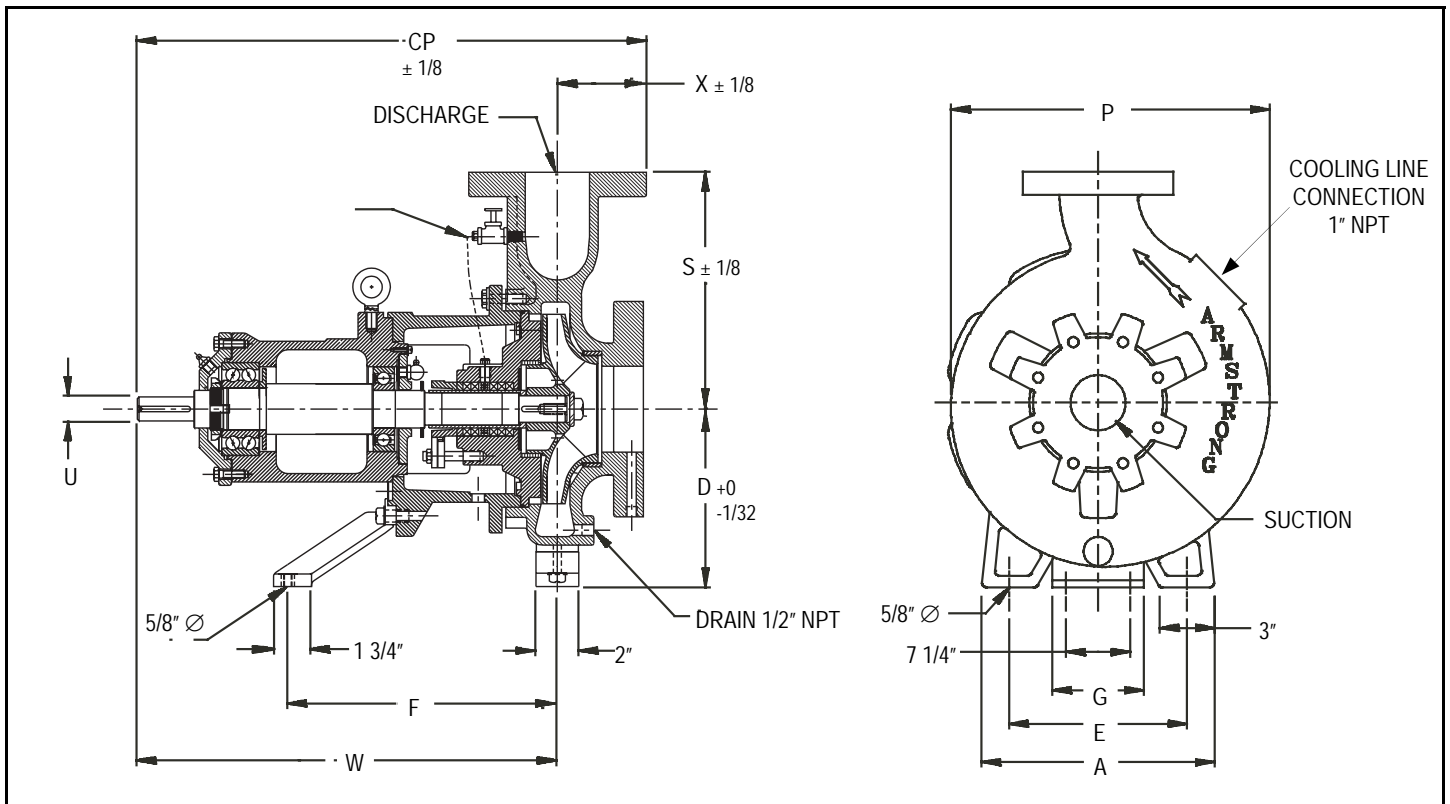

PUMP	FLANGE		DIMENSIONS (ins.)										
	SUCT.	DISCH.	D	S	U	W	X	CP	P	A	E	F	G
4 x 3 x 8.5	4	3	8 1/4	11	1 1/8	19 35/64	4	23 1/2	12 5/8	8 3/16	7	12 35/64	8 5/8

<b>FLANGE RATING</b> ANSI 125# STD (1) ANSI 250# SUCTION 250# DISCHARGE PN 16	<b>FIRE PUMP LISTING</b> UL ULC FM	<b>ACCESSORIES</b> EXHAUST SYSTEM FUEL SYSTEM COOLING SYSTEM (MOUNTED ON ENGINE) BATTERY SYSTEM
---	---	--

**DO NOT USE FOR CONSTRUCTION UNLESS CERTIFIED**

NOTE: (1) STD. DISCHARGE FLANGE THICKNESS ANSI 250#

**Armstrong Pumps Inc.**  
93 East Avenue  
North Tonawanda, New York  
U.S.A. 14120-6594  
Tel: (716) 693-8813  
Fax: (716) 693-8970  
Visit us at [www.armstrongpumps.com](http://www.armstrongpumps.com)

**S.A. Armstrong Limited**  
23 Bertrand Avenue  
Toronto, Ontario  
Canada, M1L 2P3  
Tel: (416) 755-2291  
Fax: (416) 759-9101



**Armstrong Pumps Limited**  
Peartree Road, Stanway  
Colchester, Essex  
United Kingdom, CO3 0LP  
Tel: 01206-579491  
Fax: 01206-760532

**Armstrong Darling**  
2200 Place Transcanadienne  
Montreal, Quebec  
Canada, H9P 2X5  
Tel: (514) 421-2424  
Fax: (514) 421-2436

