

JOB: _____	REPRESENTATIVE: _____
_____	_____
_____	_____
ENGINEER: _____	ORDER NO: _____ DATE: _____
CONTRACTOR: _____	SUBMITTED BY: _____ DATE: _____
	APPROVED BY: _____ DATE: _____

TAG/REF:								DWG# 1509D
PUMP DATA	FLOW	HEAD	ENGINE DATA	HP	RPM	BAT. VOLTAGE	TANK SIZE	OTHER

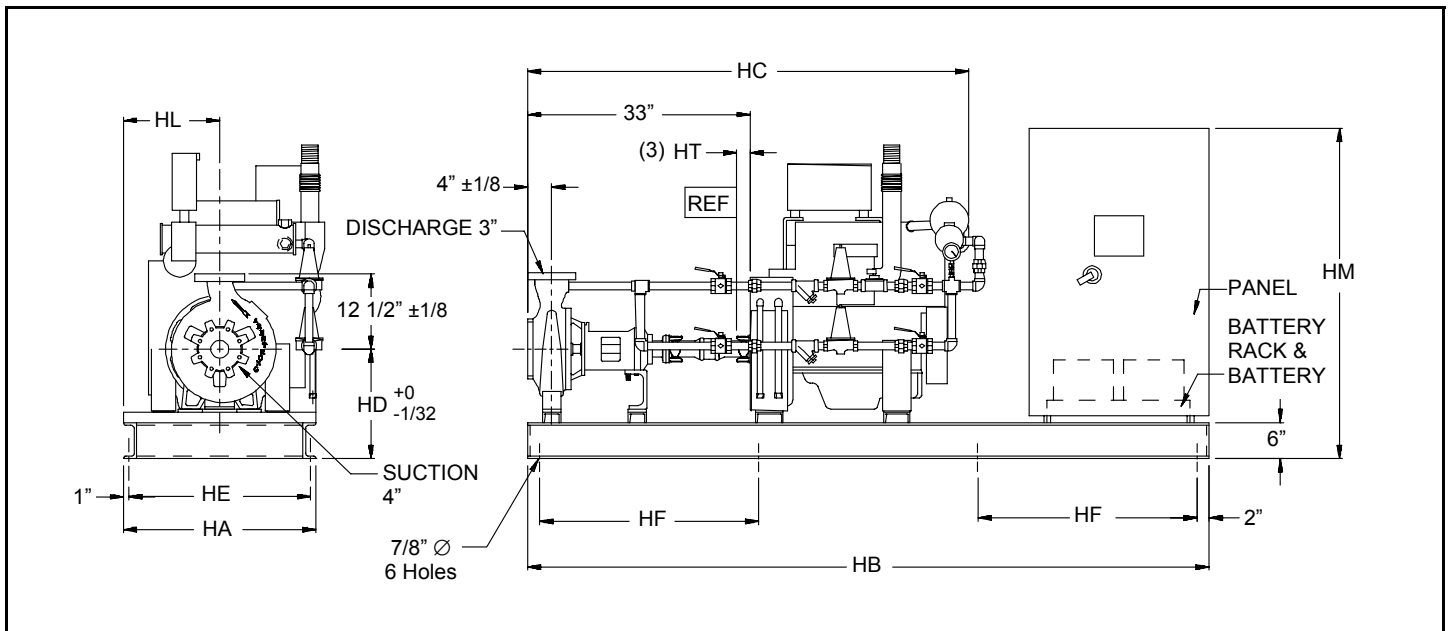

ENGINE	DIMENSIONS									WT (LBS)
	HA	HE	HL	HB	HF	HD	HM(4)	HC(4)	HT	
CLARKE VM MOTOR(VMFP) / JOHN DEERE										
JU4H-SERIES	32	30	16	120	39	22.50	55	70	-	935
VMFP-SERIES	24	21.5	12	122	34	16	55	86	-	1780

<p><b>FLANGE RATING</b></p> <p><input type="checkbox"/> ANSI 125# STD (1)</p> <p><input type="checkbox"/> ANSI 125# SUCTION</p> <p style="padding-left: 40px;">250# DISCHARGE</p> <p><input type="checkbox"/> PN 16</p> <p><b>FIRE PUMP LISTING</b></p> <p><input type="checkbox"/> UL</p> <p><input type="checkbox"/> ULC</p> <p><input type="checkbox"/> FM</p>
---

NOTE:

(1) STD. DISCHARGE FLANGE THICKNESS ANSI 250#

(2) COUPLING GUARD NOT SHOWN

**DO NOT USE FOR CONSTRUCTION UNLESS CERTIFIED**

**S.A. Armstrong Limited**  
 23 Bertrand Avenue  
 Toronto, Ontario  
 Canada, M1L 2P3  
 Tel: (416) 755-2291  
 Fax: (416) 759-9101  
 Visit us at [www.armstrongpumps.com](http://www.armstrongpumps.com)

**Armstrong Pumps Limited**  
 Peartree Road, Stanway  
 Colchester, Essex  
 United Kingdom, C03 5JX  
 Tel: 01206-579491  
 Fax: 01206-760532



**Armstrong Pumps Inc.**  
 93 East Avenue  
 Buffalo, New York  
 U.S.A. 14120-6594  
 Tel: (716) 693-8813  
 Fax: (716) 693-8970

**Armstrong Darling Inc.**  
 2200 Place Transcanadienne  
 Montreal, Quebec  
 Canada, H9P 2X5  
 Tel: (514) 421-2424  
 Fax: (514) 421-2436

