

ARMSTRONG

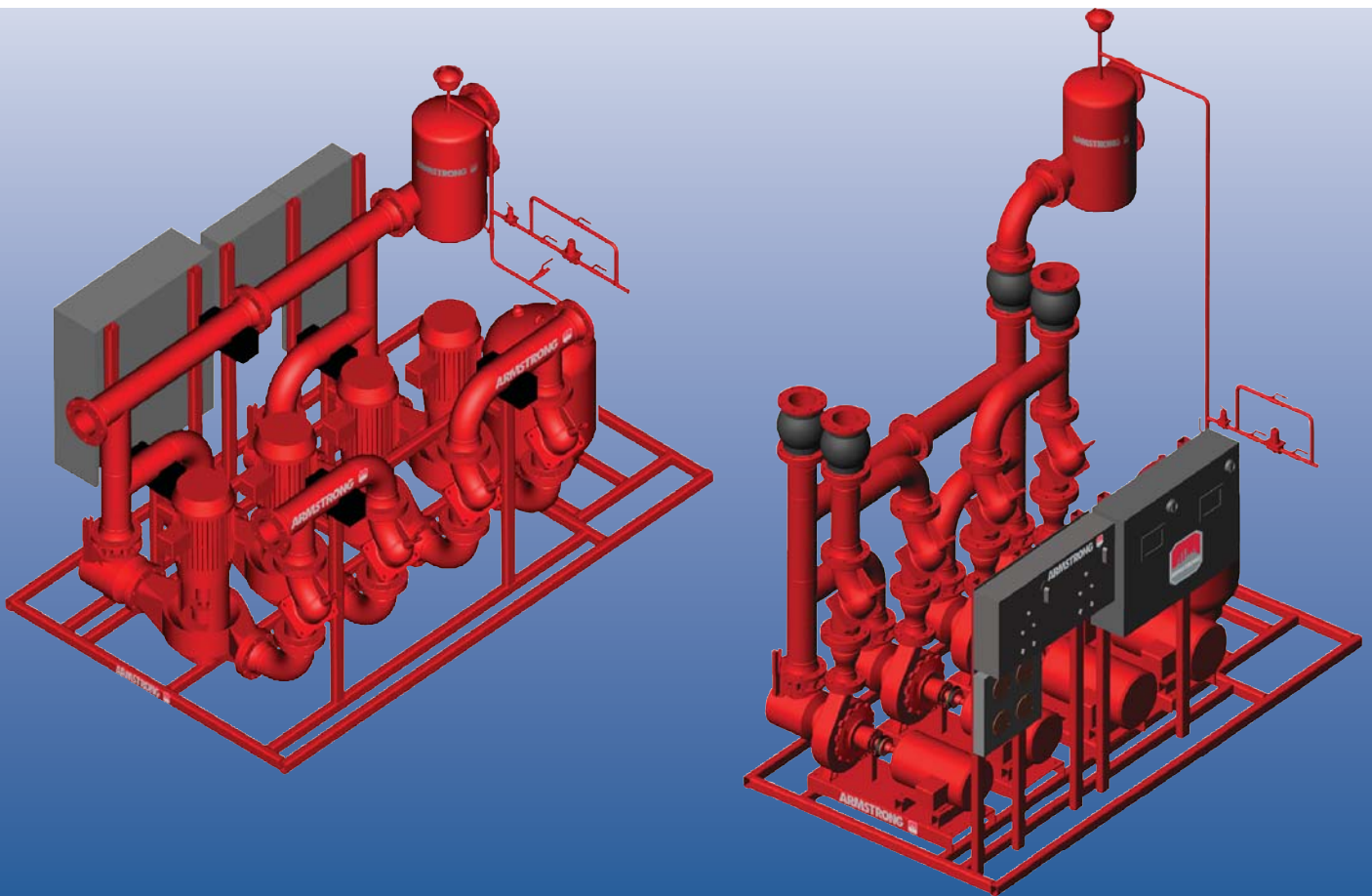

ARMkool HVAC Chilled Water Packages

FILE NO:	81.10
DATE:	Sept. 22, 2008
SUPERSEDES:	81.10
DATE:	Nov. 1, 2002

ARMkool HVAC Chilled Water Packages

Armstrong **ARMkool** Series 8100 HVAC Chilled Water Packages include a range of traditional HVAC components that are brought together in a package to:

- ▶ Save installation time
- ▶ Reduce material cost
- ▶ Improve the quality of assembly
- ▶ Provide a single source responsibility

ARMkool Series 8100 Packages are available for the following applications:

- ▶ Constant speed primary, constant speed secondary (CPCS)
- ▶ Constant speed primary, variable speed secondary (CPVS)

▶ Standard Features

The following components and features are included as standard items in all **ARMkool** packages:

- ▶ Structural steel base, suitable for grouting (floor mount systems only)
- ▶ Armstrong Series 4300 vertical in-line or Series 4030 horizontal base-mounted pumps
- ▶ IEC rated motor starters
- ▶ 6 panel-mounted pressure gauges
- ▶ Armstrong Model SG Suction Guides
- ▶ Armstrong Model FTV Flo-trex valves
- ▶ Inter-connecting piping spools and elbows, isolation valves, electrical wiring, suction and discharge headers
- ▶ Single-point electrical power connection
- ▶ Flanged connections with flexible connectors (not required on vertical pumps)
- ▶ De-coupler line
- ▶ UL Listed

▶ Optional Features

- ▶ Standby pump
- ▶ VFD on secondary pumps with manual bypass, manual speed control over-ride, one local differential pressure sensor
- ▶ Up to 16 remote zone controllers
- ▶ Sequencing option for parallel pumping
- ▶ Armstrong Vortex air separator
- ▶ Bladder style expansion tank
- ▶ Make-up water system
- ▶ BAS/BMS interface with alarms

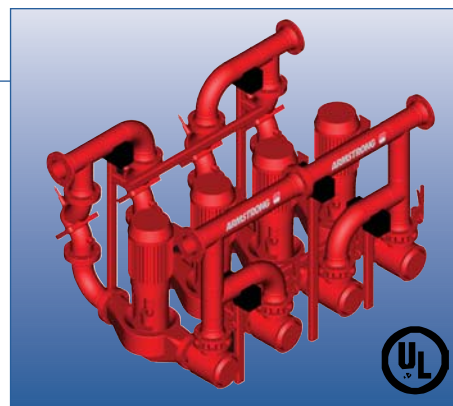

Isometric drawing of pipe-mounted HVAC Chilled Water Package showing primary and secondary pumps, inlet and outlet headers.

▶ Product Configurations

ARMkool Series 8100 Chilled Water Packages are available as:

- ▶ Floor-mounted units with horizontal pumps
- ▶ Floor-mounted units with vertical in-line pumps
- ▶ Pipe-mounted units with vertical in-line pumps

▶ Product Range

All of the **ARMkool** catalogued packages are flow and pressure tested to ensure their ratings. The following chart summarizes the **ARMkool 6** and **ARMkool 8** product range.

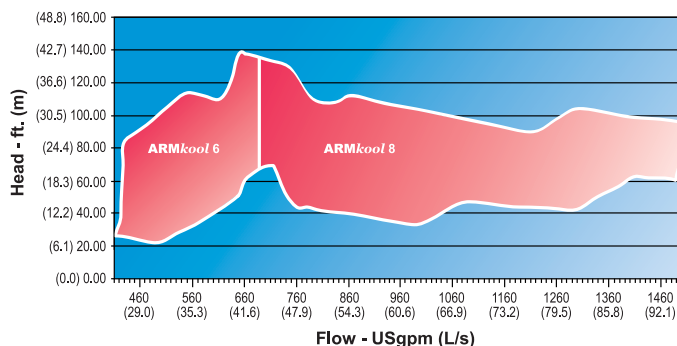

EXPERIENCE BUILDING...

S. A. Armstrong Limited
23 Bertrand Avenue
Toronto, Ontario
Canada, M1L 2P3
T: (416) 755-2291
F (Main): (416) 759-9101

Armstrong Pumps Inc.
93 East Avenue
North Tonawanda, New York
U.S.A., 14120-6594
T: (716) 693-8813
F: (716) 693-8970

Armstrong Holden Brooke Pullen
Wenlock Way
Manchester
United Kingdom, M12 5JL
T: +44 (0) 161 223 2223
F: +44 (0) 161 220 9660

ARMSTRONG 



© S.A. Armstrong Limited 2008