

ARMSTRONG

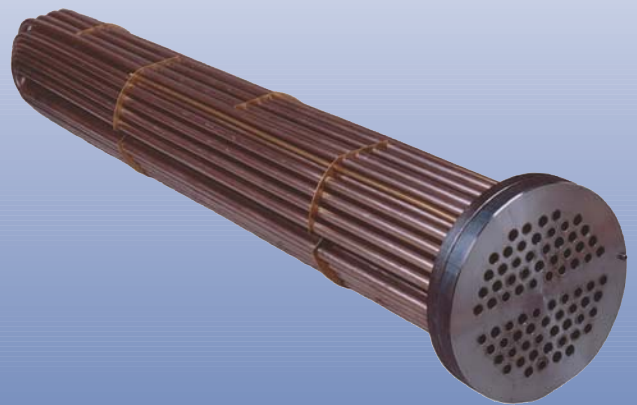
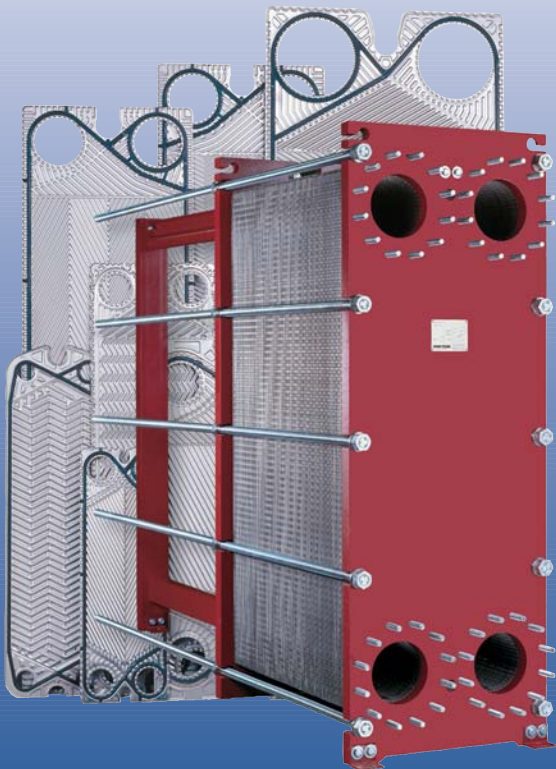

Plate & Frame, Shell & Tube and Tank Heater Tube Bundles

FILE NO:	112.09
DATE:	Nov. 17, 2008
SUPERSEDES:	112.09
DATE:	May 1, 2004

The Armstrong family of heat transfer products is aimed at providing commercial and industrial users with a proven range of heat exchanger solutions. The Armstrong range includes:

Plate & Frame Heat Exchangers

- ▶ Single or double-wall plates
- ▶ Stainless steel or titanium
- ▶ Single or multi-pass
- ▶ Brazed plate design*

Shell & Tube Heat Exchangers

- ▶ Standard or custom configurations
- ▶ Suitable for water or steam applications
- ▶ Single or double-wall tubing

Tank Heater Tube Bundles

- ▶ Suitable for water or steam applications
- ▶ Single or double-wall tubing

Armstrong's versatile heat exchangers provide dependable, efficient performance for a broad range of commercial and industrial applications where fluids must be quickly heated or cooled. Products offer industry-wide compatibility and are available in numerous material and working pressures to suit the most demanding requirements. The standard Armstrong design meets the requirements of ASME Boiler Code Section VIII, Division 1.

▶ Plate & Frame Heat Exchangers

The Armstrong plate and frame heat exchanger consists of a number of specially corrugated metal plates assembled in a frame and bolted between two pressure plates, one fixed and one adjustable. Turbulence is created in the liquid flow channels, which creates very high heat transfer coefficients and provides efficient heat transfer in a compact design. Armstrong plate and frame heat exchangers are normally supplied with stainless steel plates. Titanium plates are available as an option.

Armstrong plate designs have been optimized for water-to-water heat transfer to provide enhanced performance in HVAC applications.

Units are designed for 100 psi, 150 psi and 300 psi (690 kPa, 1034 kPa and 2068 kPa) designs. Applications requiring higher working pressures can also be accommodated.

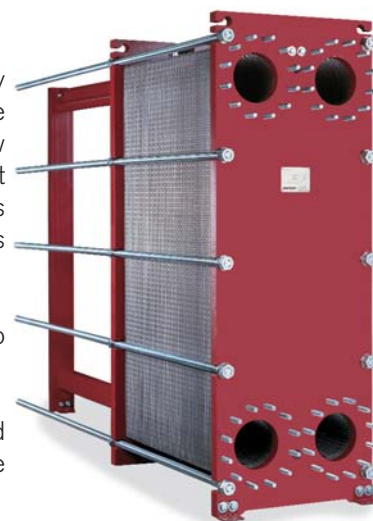

▶ Dimensions

Model	Area ft ² (cm ²)	Max. Plate Count	Nozzle Dia. inches (mm)
S7	0.7 (650)	100	1 (25)
⇕	⇕	⇕	⇕
S149	16 (14860)	600	14 (355)

▶ ABX Brazed Plate Heat Exchangers*

Armstrong offers brazed plate heat exchangers for refrigeration, hydronic heating, and process temperature control applications. The heat exchanger plates and connections are made from 316 stainless steel, to provide improved corrosion resistance. Standard designs include copper brazed plates. Nickel brazing is available as an option.

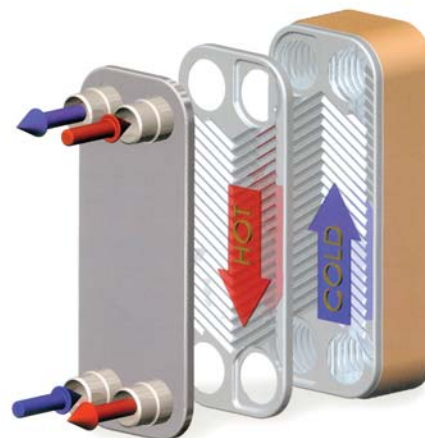

*Please contact your Authorized Armstrong Representative to review jurisdictional requirements for registration numbers on brazed plate designs.

Heat Transfer Products

► Shell & Tube Heat Exchangers



► Type W, WS, WR and U-Tube

Armstrong U-Tube heat exchangers are designed for durability and include a removable tube bundle as a standard feature. The U-shaped tube design provides a long service life by eliminating the effects of thermal expansion and contraction. These heat exchangers feature carbon steel components, 0.75" (19 mm) copper tubes, and a rugged cast iron head. Components are also available in a selection of materials for use in specific applications.

► Features

- Carbon steel shell, tubesheet and baffles
- Heavy-duty U-shaped copper tubes
- 2 and 4-pass construction
- Constructed in accordance with ASME Boiler Code Section VIII, Division 1
- 4" to 30" (102 mm to 762 mm) diameter in varying lengths
- WS - water in tubes, steam in shell
- WR - steam in tubes, fluid in shell
- W - fluid in tubes and shell

► Type WX, WSX, WRX Double-Wall and U-Tube

Double-Wall tube (tube-in-tube design) heat exchangers are designed for applications where it is critical that the system prevents the mixing of internal fluids, i.e. potable water heaters. These units, in the event of a leak, allow the liquid to drain to atmosphere. Made from the same quality components as the W Series, the tube bundle from a WX Series heat exchanger will fit the shell of an existing W Series heat exchanger.

► Options Available

- Carbon steel, brass, stainless steel or 90/10 Cu-Ni tubes
- Flanged heads with pressure rating of 150 psi (1034 kPa)
- Bronze or stainless steel heads
- 316 stainless steel shell
- Brass and 316 stainless steel tubesheets
- Brass and 316 stainless steel baffles
- Double-wall tubing with double tubesheet
- High pressure 300 psi and 400 psi (2068 kPa and 2758 kPa) designs
- Custom sizes and construction
- Designed to TEMA standards
- Carbon steel saddles

► Dimensions - inches (mm)

WS - Standard Design

E	F	G	H
28 (711)	7 (178)	16 (406)	7¼ (184)
⇕	⇕	⇕	⇕
205 (5207)	49 (1245)	144 (3668)	34½ (876)

WS - Extended Shell Design

J	K	L	M
35½ (902)	7 (178)	16 (406)	7¼ (184)
⇕	⇕	⇕	⇕
226 (5740)	49 (1245)	144 (3668)	34½ (876)

Note: All dimensions are approximate.

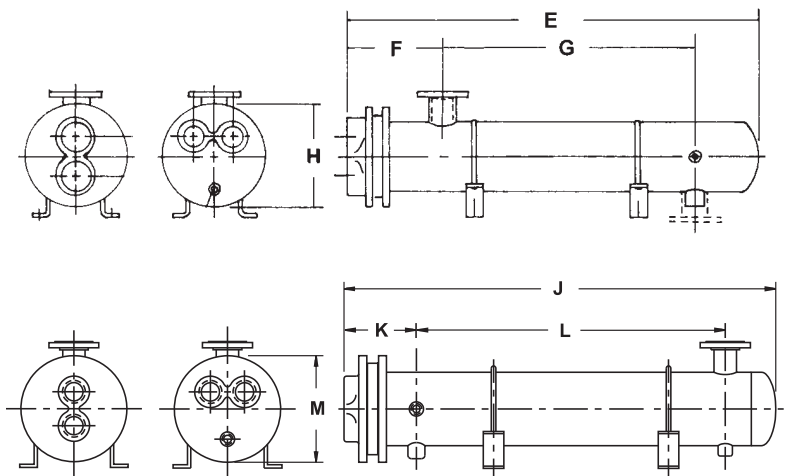

► Tank Heaters

Designed for the immersion heating of water in storage tanks, these units feature 0.75" (19 mm) copper tubing, brass tube supports, and a carbon steel tubesheet and tank collar. Tubing is available in Single or Double-Wall, copper and 90/10 Cu-Ni. Tubesheets are also available in brass or stainless steel.

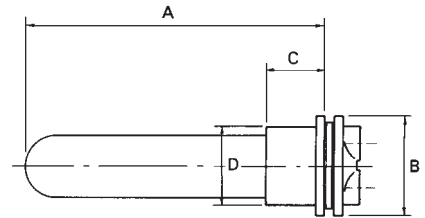

► Dimensions - inches (mm)

A	B	C	D
12 (305)	6 - 6½ (152 - 165)	4½ - 6½ (114 - 165)	7¼ (184)
⇕	⇕	⇕	⇕
162 (4115)	14 - 16½ (356 - 419)	20 - 22 (508 - 559)	24 (610)

► Typical Heating Circuit

Armstrong type WS and W Series Heat Exchangers are of shell and tube type, designed for instantaneous heating or cooling of water or other liquids.

A popular application of the WS exchangers is the heating of water with steam for hot water radiation. Armstrong W exchangers are used for heating or cooling various fluids, in applications ranging from swimming pools to industrial processes. The construction of these units depends on the fluids used in both the shell and the tubes.

Both types of exchangers are available in either 2 or 4-pass construction, the U-shaped tubes are roller-expanded into a stationary tubesheet. This design allows for the expansion and contraction caused by temperature variations. Units can be connected to any steam boiler or system, however, the capacity of the boiler must be sufficient to handle the load imposed by the heat exchanger. In addition, some method of controlling the flow to the exchanger must be provided and installed according to the manufacturer's directions.

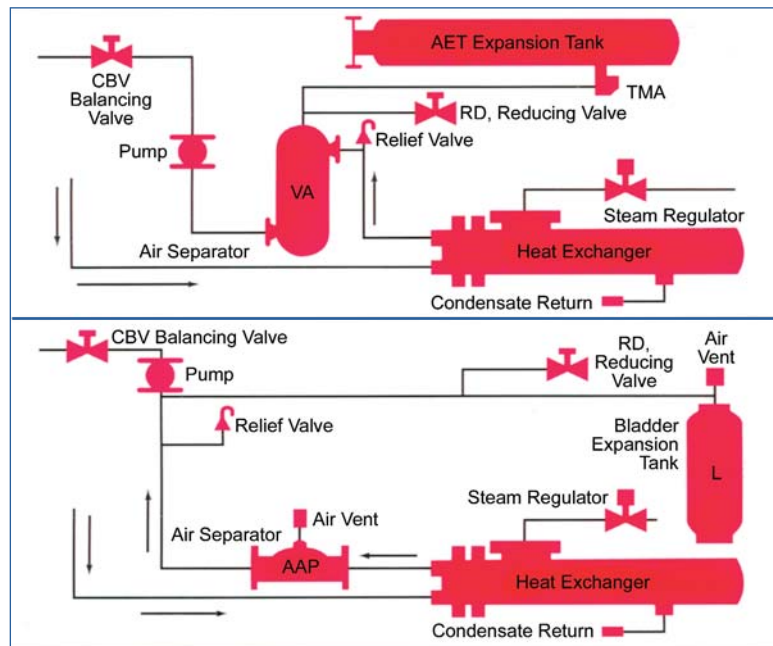

EXPERIENCE BUILDING...

S. A. Armstrong Limited
23 Bertrand Avenue
Toronto, Ontario
Canada, M1L 2P3
T: (416) 755-2291
F (Main): (416) 759-9101

Armstrong Pumps Inc.
93 East Avenue
North Tonawanda, New York
U.S.A., 14120-6594
T: (716) 693-8813
F: (716) 693-8970

Armstrong Holden Brooke Pullen
Wenlock Way
Manchester
United Kingdom, M12 5JL
T: +44 (0) 161 223 2223
F: +44 (0) 161 220 9660



© S.A. Armstrong Limited 2008

For Armstrong locations worldwide, please visit www.armstrongpumps.com