

ARMSTRONG

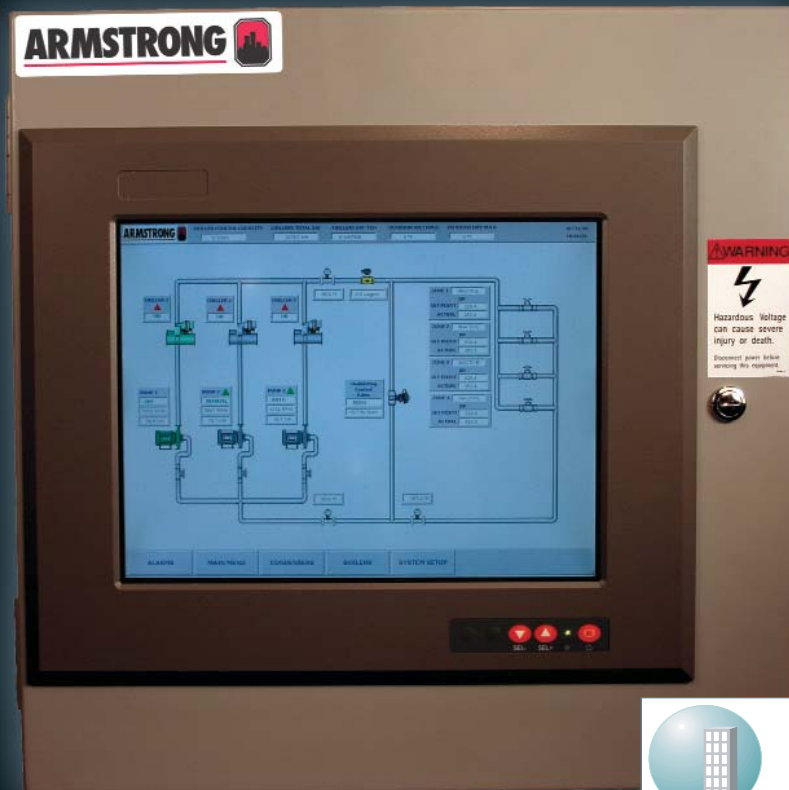

THIS PRODUCT EMPLOYS
Hartman LOOP®
TECHNOLOGIES

Ultra-Efficient Chilled Water Integrated Plant Control

FILE NO:	90.15
DATE:	Dec. 12, 2006
SUPERSEDES:	90.15
DATE:	Oct. 13, 2006

The new integrated plant control system from Armstrong:

- ▶ **Improved energy efficiency**
- ▶ **Longer equipment life and lower noise**
- ▶ **Inherently stable control algorithm**
- ▶ **All at little to no additional cost**



System designers face an ever-growing need to address the global demand for reliable, energy-efficient and cost-effective solutions.

With this in mind the Armstrong IPC 11550 ultra-efficient chilled water plant control system ushers in a new era of efficiency. Aimed at achieving better than 0.45 kW/ton (7.8 COP) operating efficiency on an annual average basis, it dramatically exceeds today's best-in-class levels of 0.75 kW/ton (4.7 COP), for water-cooled systems.

Employing the Hartman LOOP® methodology of chilled water plant control, the IPC 11550 Control System maximizes the benefits of all variable speed plant design. This is a proven control method that employs a patented technique for operating variable speed chilled water plants. Hartman LOOP® technology has been installed in several major facilities for over 5 years and continues to produce energy savings over other control methodologies.

The IPC 11550 works equally well on variable primary flow (VPF), and variable primary - variable secondary (VPVS) system configurations, as illustrated below. VPVS systems have two sets of pumps on the load side of the chillers, one set for

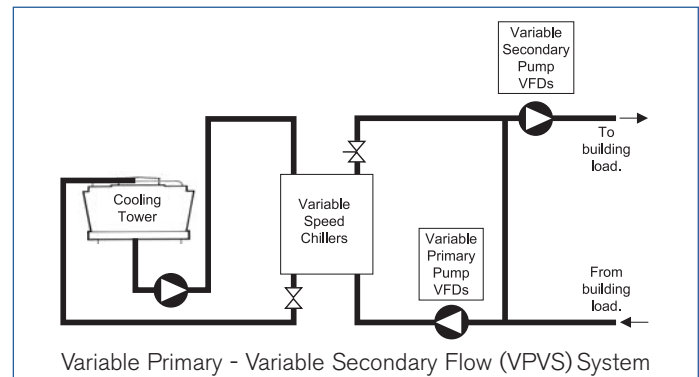
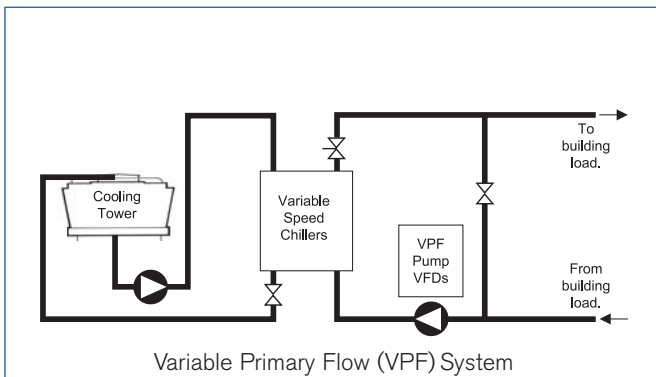

distribution and a second set for chiller flow. In contrast, a VPF system combines both pump loads onto one pump set. Both solutions have strengths to match specific applications, and the IPC 11550 can optimize either.

The IPC 11550 system architecture is based on high-level serial communication between a network of three control panels: The IPC 11550 master panel, the IPC 3500 chiller and pump control panel, and the ITC 3600 integrated tower control panel. The IPC 11550 system also provides energy savings on air-cooled systems.

The IPC 11550 system produces dramatic energy savings. In addition, in most cases the IPC 11550 system does not increase the total equipment costs of the plant. Optimizing the plant design for the HVAC characteristics of a part load application produces hardware savings to offset the small increase in technology and control costs.

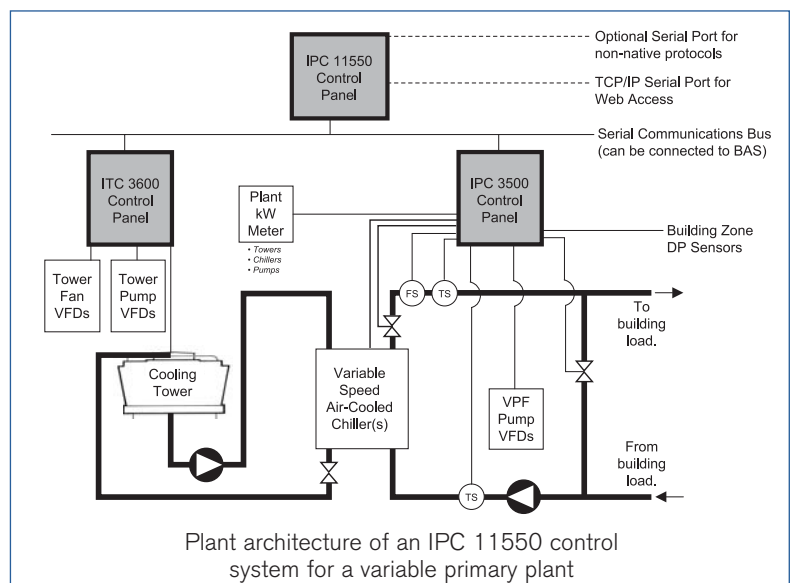

IPC 11550 System

The IPC 11550 system creates a new standard for HVAC system communications, with full remote control capabilities through web-based interfaces. Imagine being able to access your plant from anywhere in the world and being able to trouble shoot, rotate duty status of equipment, or switch out suspect hardware from service. In addition to helping predict equipment failures, a plant using the all variable speed IPC 11550 system is less likely to suffer any failures, as operating at a lower speed will extend equipment life and dramatically lower noise levels.

The IPC offers a number of dynamic user interface screens that lead the user to the desired information or action commands. All systems include 2 GB of memory for trending data. Also included are factory preset, and field adjustable warning and alarm limits on over 20 plant parameters. When these occur, the IPC can send an e-mail, send a message to the building management system and/or sound a local audible alarm.

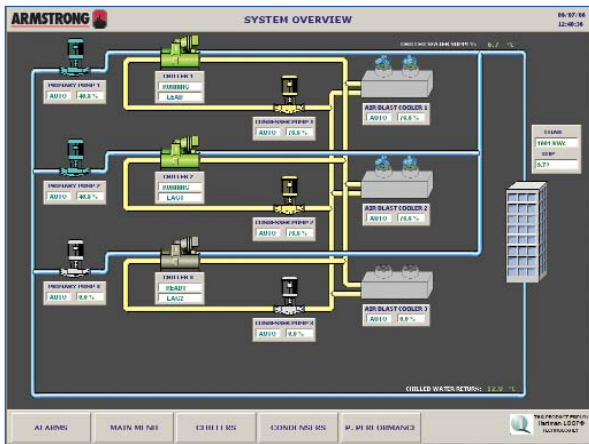

Water-Cooled Plant Overview Screen

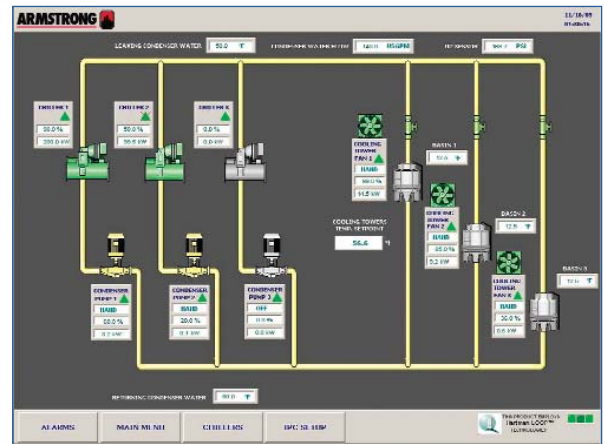

Condenser Water Circuit Screen

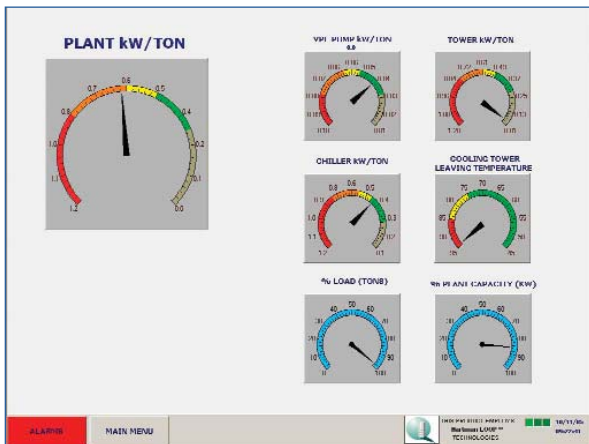

Plant Performance Meter Screen

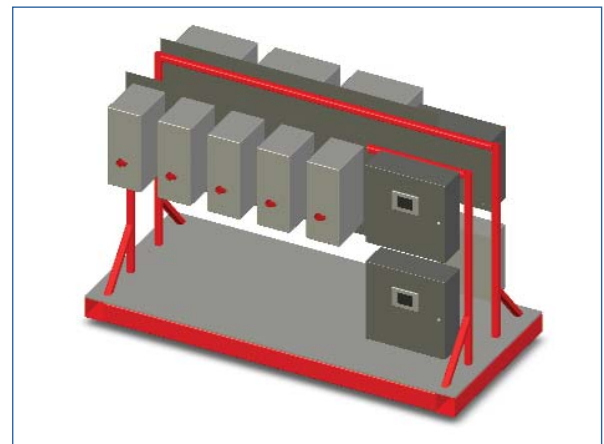

Typical Assembly

The IPC 11550 system employs the Hartman LOOP® Natural Curve sequencing logic to ensure that the variable speed chillers are always operating as close as possible to their maximum efficiency for a given entering condenser water (ECWT) or ambient air temperature. To reach the optimum ECWT, the IPC 11550 maintains the greatest active surface area on the cooling towers by slowing down the condenser water pump and tower fan, as opposed to staging off cooling towers.

Combining this with the Hartman LOOP® patented demand-based control algorithm results in one of the most stable systems conceivable.

To learn more, visit us at www.armstrongpumps.com, or The Hartman Co. at www.hartmanco.com.

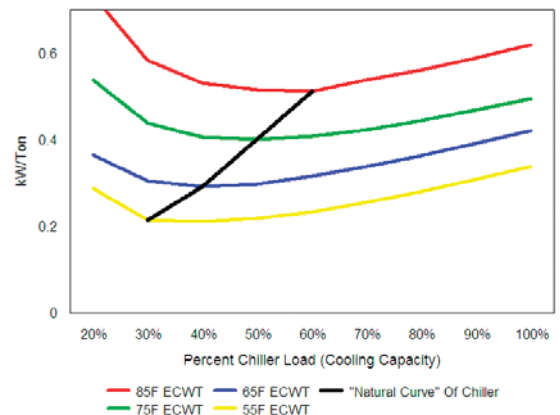

IPC 11550 - Ultra Efficient Chilled Water Plant Control System

► Features & Benefits

- An "all-variable speed" plant controller with true integrated system logic
- Ultra-efficient plant operation with annual average plant efficiency of 0.45 kW/ton (7.8 COP) for compliant water-cooled "all variable speed" plant designs* and 0.95 kW/ton (3.7 COP) for air-cooled plants
- Plant mechanical equipment is operated at a lower load and speed, relative to other plant control methods, leading to; efficiency, prolonged equipment lifespan, lower maintenance costs, and lower plant dB levels
- **Prefabricated control assembly** - Facilitates easy installation of control system and decreases on-site labor
- **Single point wiring** - Limits the amount of field wiring needed
- **Numbered terminal block** - Facilitates easy wiring between control system components
- **Panel PC with 15" LCD touch-screen** - Provides a simple and effective way to navigate through the system without the use of peripheral devices
- **Automatic e-mail notification for chilled water plant alarms** - Improves response time for service and helps prevent equipment breakdown
- **Remote internet access** - Enables users to control and monitor the chilled water plant from a remote location
- **Onscreen Name Plate data display for chilled water plant equipment (Pumps, chillers, cooling towers, etc.)** - Provides easy access of equipment information for service and maintenance purposes
- **Onscreen Installation and Operation Manual display for chilled water plant equipment (pumps, chillers, cooling towers, etc.)** - Easy access of equipment installation guidelines for service and maintenance purposes
- **Data and alarm logging** - Provides users with plant data and alarm history for troubleshooting and monitoring
- **Data backup through e-mail** - Allows users to back up important information directly to external devices through e-mail
- **User adjustable trending capabilities for over 30 variables including: plant power consumption, plant efficiency, chilled water supply and return temperature, and entering and leaving cooling tower temperatures** - Enables users to analyze multiple plant variables at the same time, improving troubleshooting
- **Availability of BACnet, LonWorks, Metasys, Modbus, TCP/IP communication protocols** - Increases compatibility with equipment and BMS providers
- **Back up control incase of main panel failure** - Chilled water plant will continue to operate if there is a main panel failure
- **Flash Memory** - Enables critical information to be saved when there is a power failure
- **3 level password protection** - Protects control logic and set points from tampering
- **End of curve protection** - Helps in providing a longer pump life as while decreasing noise and vibration levels

*Annual average plant efficiencies for all variable speed plant design with plant equipment IPLV efficiencies compliant with the Armstrong IPC 11550 System specification.

EXPERIENCE BUILDING...

S. A. Armstrong Limited
23 Bertrand Avenue
Toronto, Ontario
Canada, M1L 2P3
T: (416) 755-2291
F (Main): (416) 759-9101

Armstrong Pumps Inc.
93 East Avenue
North Tonawanda, New York
U.S.A., 14120-6594
T: (716) 693-8813
F: (716) 693-8970

Armstrong Integrated Systems Limited
Mucklow Hill
Halesowen, West Midlands
United Kingdom, B62 8DJ
T: +44 (0) 121 550 5333
F: +44 (0) 121 550 1679



© S.A. Armstrong Limited 2006

For further details, visit www.armstrongpumps.com or www.armstrongintegratedsystems.com