

ARMSTRONG

Series 6000



FILE NO: 62.10
DATE: Feb. 15, 1999
SUPERSEDES: 62.10
DATE: Dec. 15, 1997

Hydropak Booster Systems

Series 6000 Hydropak



Armstrong Pumps introduces the Series 6000 **HYDROPAK** line of packaged booster systems. Series 6000 **HYDROPAK** applications include commercial, high rise, industrial and other installations requiring a boost in water pressure.

The Series 6000 **HYDROPAK** fulfills the need for an engineered, compact, ready to install and factory tested booster system.

Responding to flow & pressure demands, the **HYDROPAK** is equipped with an autonomous, state of the art control system that provides uninterrupted, unattended pump operation in the most energy efficient way.











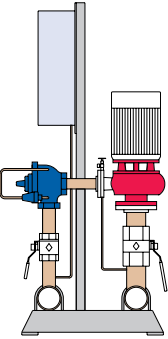

▲ MODEL 6722 SHOWN ▲

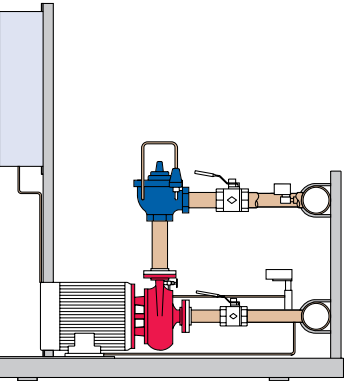
Benefits

- Single source responsibility.
- Fully factory assembled, tested, and UL labeled
- Quality engineered components.
- Compact design minimizes floor space.
- Standard Series 6500 & 6600 systems for flows up to 500 usgpm are engineered to fit through 34" doorway.
- Angled Pressure Reducing Valves (PRV's) minimize internal pressure drops.
- Available piping materials are copper, stainless steel or galvanized steel.
- Headers are available in copper, stainless steel, galvanized steel and cast iron.
- Header connections supplied grooved or flanged.
- Savings of up to 30% on annual energy operating costs.
- Proven Armstrong vertical in-line, end suction (horizontal or vertical), or vertical MultiStage pumps.

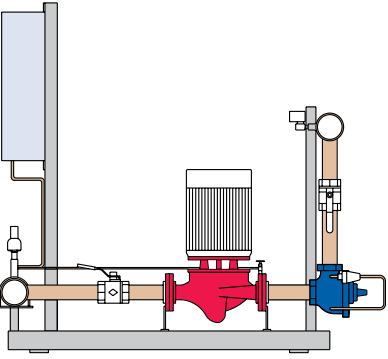
Series 6000 Booster Selection Criteria

Standard Series 6000 **HYDROPAK** packages are designed to satisfy most applications and offer choices as to pump model and type with a basic control logic to allow worry free operation and respond to varying load demands.

| | | | | |
|---|--|---|-----------------|-------------------|
|  | <p>SERIES 6500</p> <ul style="list-style-type: none"> • Maximum Flow/USgpm 500 • Maximum Boost/psi 140 • Header sizes - 3" or 4" • PRV or check valve sizes 1½" - 4" | * Pump Series | Number of Pumps | Booster Model No. |
| | | 4270 | 2 | 6524 |
| | |  | 3 | 6534 |
| | | 4280 | 2 | 6525 |
| | |  | 3 | 6535 |
|  | <p>SERIES 6600</p> <ul style="list-style-type: none"> • Maximum Flow/USgpm 1000 • Maximum Boost/psi 190 • Header sizes - 3", 4" or 6" • PRV or check valve sizes 1½" - 4" | * Pump Series | Number of Pumps | Booster Model No. |
| | | 4270 | 1 | 6614 |
| | |  | 2 | 6624 |
| | | | 3 | 6634 |
| | | 4280 | 1 | 6615 |
| | |  | 2 | 6625 |
| | | | 3 | 6635 |
| | | 4030 | 1 | 6616 |
| | |  | 2 | 6626 |
| | 3 | 6636 | | |
|  | <p>SERIES 6700</p> <ul style="list-style-type: none"> • Maximum Flow/USgpm 1000 • Maximum Boost/psi 240 • Header sizes - 3", 4" or 6" • PRV or check valve sizes 1½" - 4" | * Pump Series | Number of Pumps | Booster Model No. |
| | | 4360 | 1 | 6711 |
| | |  | 2 | 6721 |
| | | | 3 | 6731 |
| | | 4380 | 1 | 6712 |
| | |  | 2 | 6722 |
| | | | 3 | 6732 |
| | | 4300 | 1 | 6713 |
| | |  | 2 | 6723 |
| | | | 3 | 6733 |
| | | 4700 | 1 | 6717 |
| | |  | 2 | 6727 |
| | 3 | 6737 | | |

* For selection use ArmCalc or ACE Pump select software.

Booster Model Selection

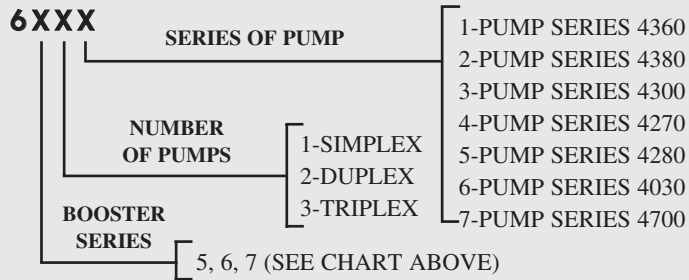

Custom Packages

Armstrong recognizes the need for “customized packages”. Our team of systems engineers working with the latest technology in Computer Aided Drawing will recommend the optimal system for your specific application, including 50 cycle operation.

Hydropak Hydrosaver

Conventional sizing criteria using equal capacity pumps to satisfy water demand in a multipump system may not result in the most energy efficient arrangement for applications with fluctuating load demands.

HYDROPAK HYDROSAVER is a tailored approach to pump selection intended to reduce energy consumption by 5-30% according to the specific duty cycle. A conventional duplex system, with equal capacity pumps, is limited to 2 step operation (50-100%) of demand. For the same application the **HYDROSAVER** would provide 3 step operation (33-67-100%) of demand.

Respectively in a triplex system the conventional is limited to 3 step (33-67-100%) versus 5 step (20-40-60-80-100%) for the **HYDROSAVER**.

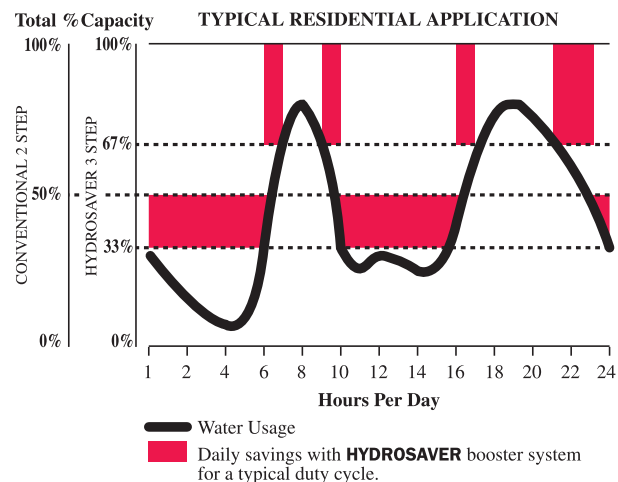

Hydropak Standard Equipment Included

- Pump inlet & outlet isolation valves.
- Pilot operated pressure reducing valves.
- Common headers complete with interconnecting pipes & fittings.
- Thermal bleed circuit consisting of emersion aquastat and solenoid valve.
- Inlet and outlet pressure gauges.
- Factory wiring.
- Calibration and testing of system.
- Factory mounting and painting of pumps, valves, piping and control panel on base.



▲ TANK ▲

Options

- No flow shut down with drawdown tank (mounted or supplied loose). Allows pumps to be shutdown during periods of no demand.
 - Non-slam check valves in place of pressure reducing valves.
 - Gate valves in place of standard ball valves.
 - Choice of piping and header materials.
 - Individual pump thermal protection.
-

Controls Panel Standard Features

- UL508/CSA approved
 - Nema 1 enclosure
 - Single power supply connection
 - Across the line magnetic starters
 - 3 leg motor overload protection (internal reset)
 - Electrical interlock between starters
 - Current sensing relay sequencing
 - Motor protector circuit breakers
 - Minimum run timers
 - Thermal bleed circuit to activate emersion aquastat and solenoid valve
 - Low suction pressure protection with indicating light
 - Power on pilot light
 - Individual pump running light
-

Control Panel Options

- Automatic pump alternation
- 24 Hour weekly time clock
- Pump elapsed time meter
- NEMA 12, 3, 4x enclosures
- Programmable logic controller
- Flow sequencing with impeller wheel type instrument
- Pressure sequencing
- High suction pressure cut-out
- High discharge pressure cut-out
- Lead pump failure protection (low discharge pressure)
- Night time shutdown with pressure override
- Remote signaling and alarm contacts
- **HYDROSAVER** duplex units with 3 step staging
- **HYDROSAVER** triplex units with 4 step staging
- **HYDROSAVER** triplex units with 5 step staging

Engineers Specifications

Series 6000 Hydropak Booster System

1.0 GENERAL

Furnish and install, as shown on the plans and specifications, an Armstrong Model _____ (Simplex, Duplex or Triplex) Packaged Booster System. Designed for a total system capacity of _____ USgpm with a total discharge head of _____ psi, including a minimum suction pressure of _____ psi.

1.1 PUMPS

The pumps shall be Armstrong series (4360, 4380, 4300, 4270, 4280, 4030 and 4700) complete with bronze (or resin) fitted dynamically balanced impellers, mechanical seal, (125 or 250) psi suction and discharge flanges, pumps (vertically or horizontally) mounted with (ODP or TEFC) squirrel-cage induction motors suitable for operation with _____ volts, 3 phase, 60 hertz power supply. Pumps shall be of the (vertical in-line, end suction, or vertical multi-stage) design, single stage centrifugal type with cast iron casing. Pumps shall be manufactured by the booster supplier.

1.2 PUMPING DETAILS

P1 Series: _____ Size: _____, Capacity: _____ USgpm at _____ feet of head with _____ hp, _____ rpm motor.

P2 Series: _____ Size: _____, Capacity: _____ USgpm at _____ feet of head with _____ hp, _____ rpm motor.

P3 Series: _____ Size: _____, Capacity: _____ USgpm at _____ feet of head with _____ hp, _____ rpm motor.

1.3 ASSEMBLY

All interconnecting piping to be (type L or K copper, galvanized steel or stainless steel). Common suction and

discharge (type L or K copper, galvanized steel, stainless steel, or cast iron) headers with (grooved ends or flange adapter). The assembly shall be complete with bronze ball valves, epoxy coated cast iron combination pilot operated pressure reducing and check valves, 4" diameter 0-200 psi suction and 0-300 psi discharge pressure gauges, pump thermal relief circuit including aquastat, solenoid valve, and wiring conduits.

1.4 CONTROL PANEL

The control panel shall be of the (current sensing relay sequencing or peddle wheel type flow sequencing based on pressure for lead pump and flow for remaining pumps). The complete control panel assembly and all internal devices shall be UL508/CSA approved. The panel shall be complete with NEMA (1, 12, 3 or 4X) enclosure and include door interlocked main disconnect and magnetic motor starters with (fused or fuseless) motor protectors, adjustable time delays, H-O-A selector switch for each pump, power on light, minimum run timers, low suction pressure switch and pilot light, 120 V control transformer with protected control circuit. Control circuit to include fault relay circuit to turn on the next pump should the lead pump fail.

1.5 TESTING

The system shall be factory assembled, wired, performance tested, calibrated and shipped ready to receive piping and wiring. The entire package shall be UL listed and shall be assembled at an ISO 9001 manufacturing Facility.

Armstrong Pumps Inc.
93 East Avenue
North Tonawanda, New York
U.S.A. 14120-6594
Tel: (716) 693-8813
Fax: (716) 693-8970

Armstrong Holden Brooke Pullen
Wenlock Way
Manchester
United Kingdom, M12 5JL
Tel: +44 (0) 161 223 2223
Fax: +44 (0) 161 220 9660



S.A. Armstrong Limited
23 Bertrand Avenue
Toronto, Ontario
Canada, M1L 2P3
Tel: (416) 755-2291
Fax: (416) 759-9101

Armstrong Darling
9001 De L'Innovation, Suite 200
Montreal (Anjou), Quebec
Canada, H1J 2X9
Tel: (514) 352-2424
Fax: (514) 352-2425

