

# ARMSTRONG

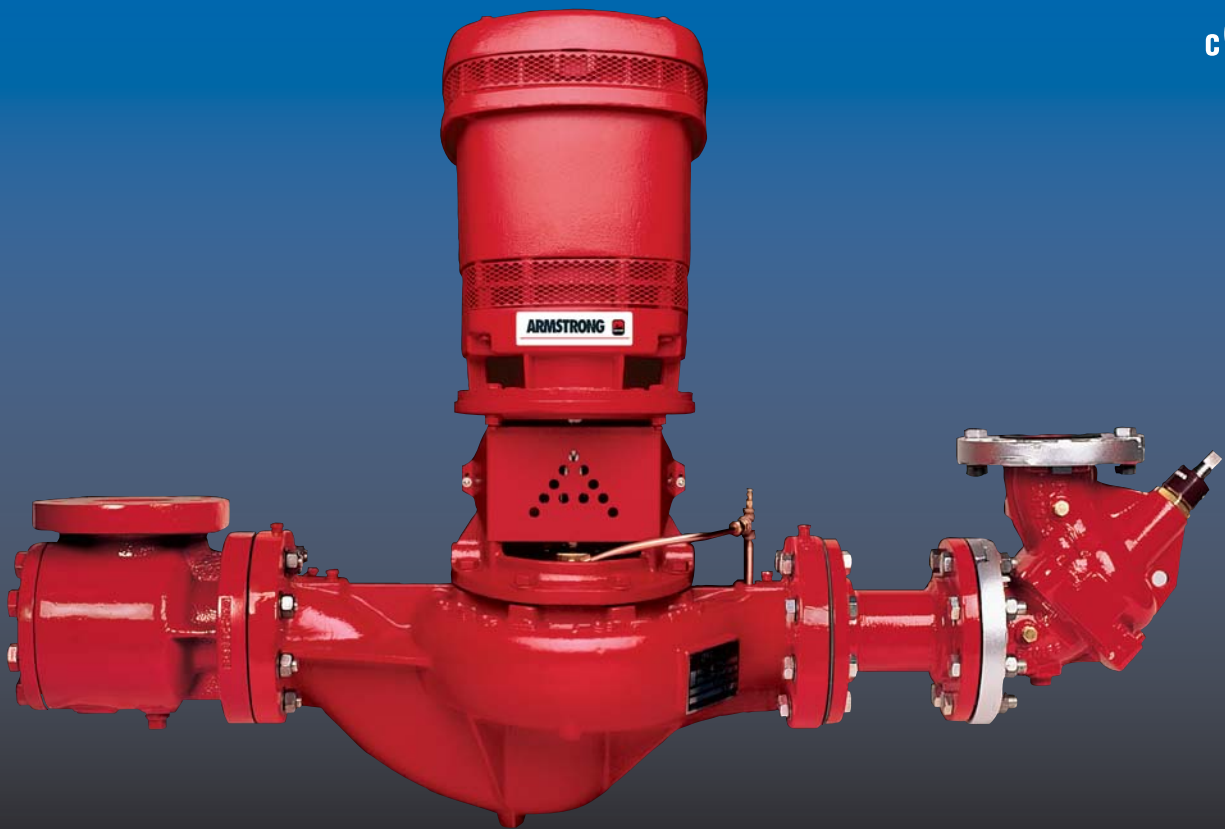

## Series SG & Series FTV

FILE NO:	35.11
DATE:	Nov. 14, 2009
SUPERSEDES:	35.11
DATE:	April 13, 2009

# Suction Guides

**Designed for direct mounting on the suction flange of horizontal and vertical pumps.**



## Armstrong Suction Guide Design:

- Model SG: Supplied with cast iron body and ANSI-125/PN16 flanges.
- Model SGG: Supplied with ductile iron body with grooved inlet connection and ANSI-125/PN16 outlet flange.
- Model SGHH: Supplied with ductile iron body and ANSI-250/PN25 flanges.

## ► Model SG, SGG and SGHH Suction Guides

### Four-function pump fitting

#### ► 90° Elbow

Mounting the Suction Guide on any pump suction turns the piping 90°, replacing an elbow. In addition, the Suction Guide can be rotated to any position allowed by the pump suction bolts, from vertical to horizontal.

#### ► In-Line Strainer

The stainless steel strainer has free area of at least 250% of pipe sectional area. A disposable fine-mesh strainer is installed for start-up cleaning.

#### ► Reducing Elbow

The Suction Guide connects same size piping to the pump suction, but can also connect to inlet piping one size larger than the pump suction, eliminating a reducing elbow.

#### ► Guide Vanes

Flow stabilizing vanes on the outlet allow the Suction Guide to bolt directly to the pump, saving the space and cost of a long straight pipe length.

# Flo-Trex Valves

**Designed for installation on the discharge side of centrifugal pumps.**

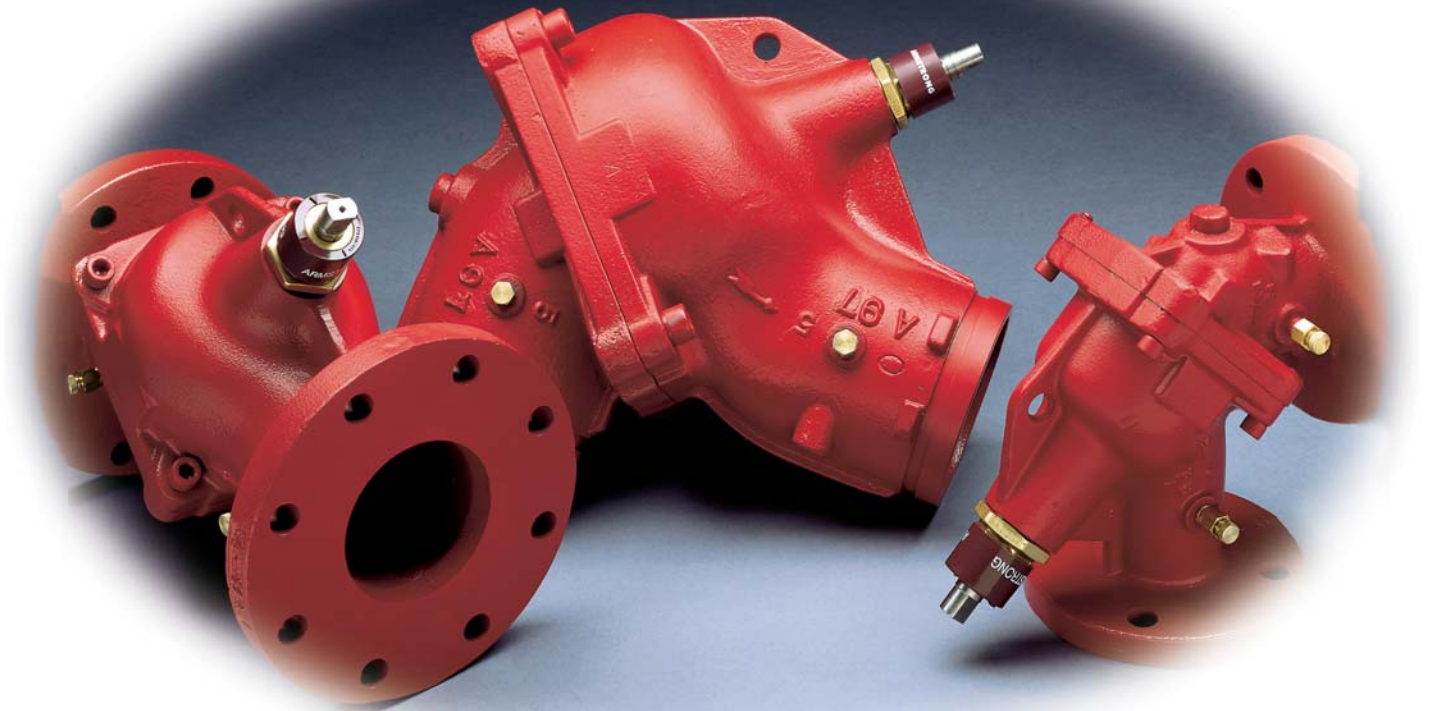

## Armstrong Model FTV Flo-Trex Combination Valves

**Model FTV-F:** Flo-Trex valve is supplied with hard (cast-in) flanges.

**Model FTV-G:** Flo-Trex valve is supplied with grooved port connections, designed for Armstrong Armgrip™ flange adapters or standard grooved pipe fittings.

### ► Model FTV Flo-Trex Valves

#### ► Drip-tight Shut Off Valve

The Armstrong Flo-Trex valve is designed and tested for drip-tight isolation at 150% of maximum working pressure.

#### ► Non-slam Check Valve

The Armstrong Flo-Trex valve incorporates a spring closure design that closes the valve in a controlled manner, protecting the valve from slamming due to a reversal in flow caused by gravity or recirculation from a parallel pump.

#### ► Flow Throttling Valve

The Armstrong Flo-Trex valve uses a plug and disc design which is the most effective valve type for combining throttling of flow and isolation. Other design valves may be effective for throttling or isolation, but not both.

#### ► Convertible Body Design

The Armstrong Flo-Trex convertible body design permits the valve to be changed on-site from straight to angle configuration.

# Armstrong Suction Guides and Flo-Trex Valves...

- ▶ Fewer components required as redundant fittings are eliminated.
- ▶ Fewer connections required with Armstrong's multi-purpose fittings.
- ▶ Less installation time required by reducing the number of fittings.
- ▶ Less installation space required as pump inlet spool piece is eliminated.

## Armstrong Method

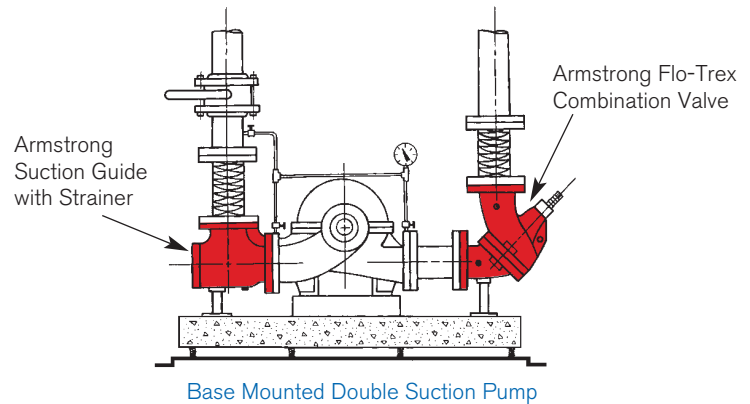
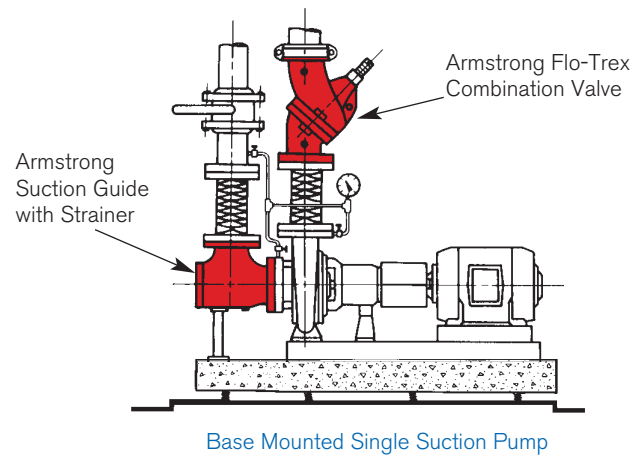

## ▶ The Smart Choice

An Armstrong Vertical In-Line Pump installation requires the fewest components and connections, maximizing savings and minimizing installation time.

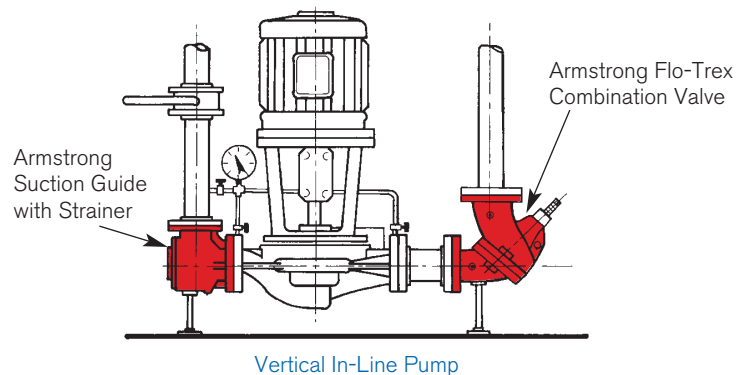

# Reduce Field Installation and Materials Costs

## Conventional Method

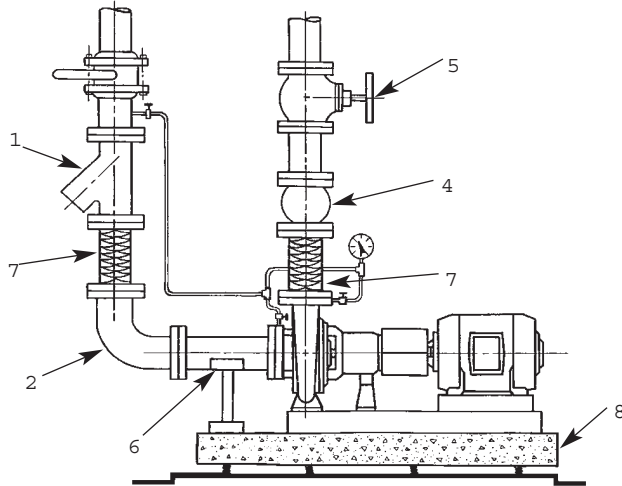

Base Mounted Single Suction Pump

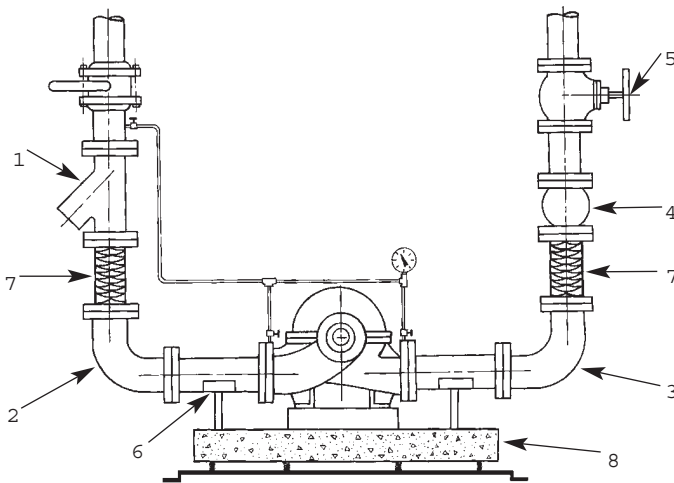

Base Mounted Double Suction Pump

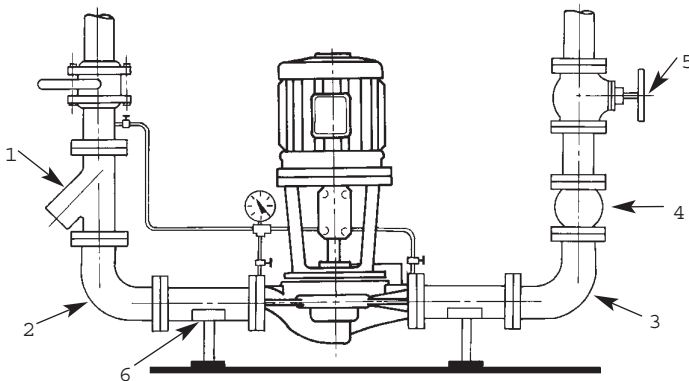

Vertical In-Line Pump

Components eliminated using Armstrong Flo-Trex Valves and Suction Guide strainer for base mounted single and double suction pump installations and Vertical In-Line installations:

1. "Y" Strainer
2. Suction long radius elbow
3. Discharge long radius elbow
4. Discharge check valve
5. Discharge globe valve
6. Suction pool piece

In addition, use of the FTV-G style eliminates three welded flange connections.

Additional components eliminated using Armstrong Vertical In-Line pumps with Flo-Trex Valves and Suction Guide strainers in place of base mounted applications:

7. Flexible connectors
8. Inertia base isolation
9. Field shaft alignment (not shown)

# Materials of Construction

## ► Suction Guides

Model	Body	Cover	Strainer	Fine-Mesh	Guide Vanes
			1/8" (3 mm) Perforations	Fine-Mesh Strainer	
SG	Cast	Ductile	Stainless	Galvanized	Cast
	Iron	Iron	Steel	Steel	Iron
SGG, SGHH	Ductile	Ductile	Stainless	Galvanized	Ductile
	Iron	Iron	Steel	Steel	Iron

## ► Flo-Trex Valves

Model	Body	Disc	Stem & Spring	Seat & O-Ring	Port Fitting
FTV-F ANSI-125/PN16	Cast	Bronze	Stainless	EPDM	Brass
	Iron		Steel		
FTV-F ANSI-250/PN25	Ductile	Bronze	Stainless	EPDM	Brass
	Iron		Steel		
FTV-G	Ductile	Bronze	Stainless	EPDM	Brass
	Iron		Steel		

### Suction Guide Body

Cast iron, or ductile iron, with ANSI or PN16 flanges. Same size ports are available with oversized inlet flange to eliminate reducer.

### Guide Vanes

Stabilizing vanes reduce turbulence, thereby creating optimum flow conditions and minimizing stress on pump components.

### Strainer

1/8" (3 mm) perforated stainless steel, star-shaped for added strength, designed to provide large free flow area to reduce pressure drop.



Armstrong Model SG Suction Guide

### Start-up Strainer

Removable fine mesh strainer, furnished as a standard item, helps prevent mechanical seal or instrument damage during initial run period.

Optional magnet to help eliminate free floating metallic particles from system.

Removable cover, with O-ring, enables easy access to strainer.

## Maximum Operating Parameters

### Suction Guide & Flo-Trex Pressure/Temperature Parameters

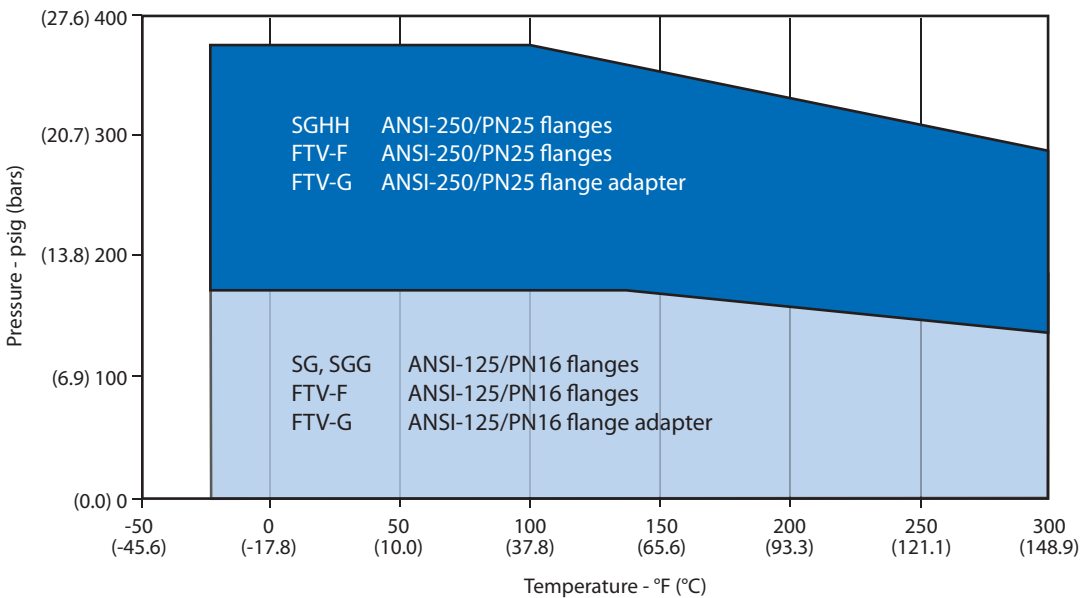

# Technical Information

## Design Benefits

- ▶ Reduced field installation and material costs.
- ▶ Cast iron or ductile valve body with hard flanges, or ductile iron valve body with standard grooved ends.
- ▶ Eliminates requirement for two separate valves on pump discharge and, in some cases, a 90° elbow.
- ▶ FTV-G eliminates three welded flange connections.
- ▶ Soft seat to ensure tight shut-off.
- ▶ Spring-closure design uses a non-slam silent check valve feature for vertical mounting.
- ▶ Flow measurement and pump throttling capabilities.
- ▶ Temperature measurement capability.
- ▶ Spring-closure design check valve prevents gravity or reverse circulation when pump is not operating.
- ▶ Bonnet "O" Ring can be replaced under full system pressure by back seating of valve stem.
- ▶ Suitable for maximum working pressure up to 375 psi (26 bars) and temperatures up to 300°F (150°C).
- ▶ Valve seat can be changed in the field without use of special tools.
- ▶ Low pressure drop due to "Y" pattern valve design.
- ▶ Valve  $C_v$  designed to ASHRAE flow recommendations for quiet system operation.

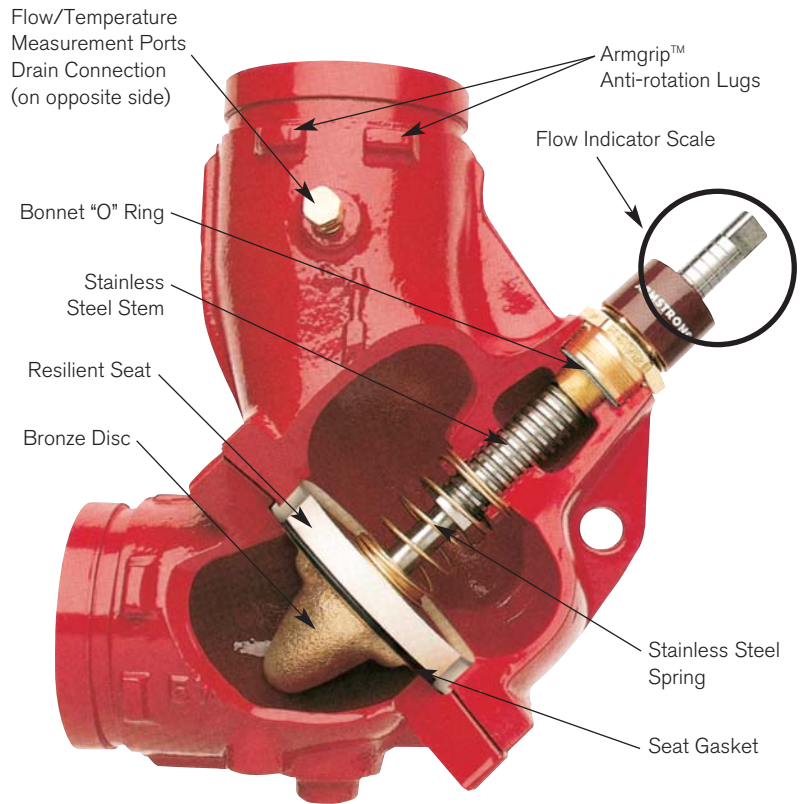

Armstrong Model FTV-GA Flo-Trex Valve

### ▶ Flow Indicator Scale

The valve stem, with its grooved rings and positioning sleeve, indicates the throttle position of the valve. The quarter turn graduations on the sleeve, with the scribed line on the stem, provide for approximate flow measurement.

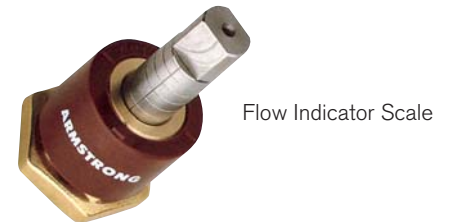

Armstrong Armgrid™ Flange Adapter



Gasket

### ▶ Hard Flanged Body or Armgrid™ Flange Adapter

The hard flanged body or the combination of the Armstrong flange adapter and Flo-Trex body, equipped with the unique Armgrid™ anti-rotation lugs, ensures a rigid pump installation.

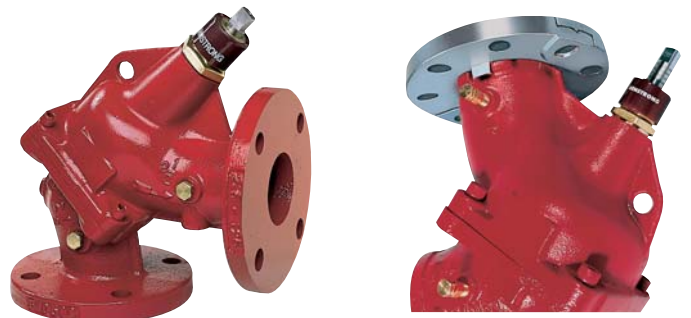

# Typical Specification - Pump Trim

## Suction Guides

Furnish and install on the suction of each pump an Armstrong Suction Guide, with outlet flow stabilizing guide vanes, removable stainless steel strainer, fine mesh start-up strainer and plugged inlet gauge tapping.

For 150 psig/PN16 flanged pipe - Supply valve with cast iron body with ANSI-125/PN16 flanged ports.

For 150 psig grooved systems - Supply valve with ductile iron body with grooved inlet connection and ANSI-125/PN16 outlet flange.

For 300 psig/PN25 flanged pipe - Supply valves with ductile iron body and ANSI-250/PN25 flanged ports.

The mechanical contractor shall inspect the strainer prior to activating the pump and, further, shall remove the fine mesh start-up strainer after a short running period (24 hours maximum). Space shall be provided for removal of the strainer and connection of a blow-down valve.

## Flo-Trex Valves

Furnish and install on the discharge side of each pump an Armstrong Model FTV Flo-Trex Combination Valve. Each valve is to incorporate the following three functions in one body: Tight shut-off, spring-closure type silent non-slam check and effective throttling with flow measurement capability. The body shall have (2) 1/4" NPT connections on each side of the valve seat. Two connections to have brass pressure and temperature metering ports, with Nordel check valves and gasketed caps. Two other connections to be supplied with brass drain plugs. Metering ports are to be interchangeable with drain ports to allow for measurement flexibility when installed in tight locations. The valve disc shall be bronze plug & disc type with high impact engineered resin seat to ensure tight shut-off and silent check operation.

The valve stem shall be stainless steel with flat surfaces provided for adjustment with open-end wrench.

### For Grooved Piping:

Valve body shall be ductile iron with grooved ends and Armstrong anti-rotation Armgrip™ lugs on the inlet and outlet of the body.

Flange adapters, where necessary, are to be Armstrong Armgrip™ ANSI-125/PN16 or ANSI-250/PN25 ductile iron flanges with anti-rotation lugs and EPT gaskets.

### For Welded Flange Piping:

For 150 psig/PN16 flanges - Valve body shall be cast iron with ANSI-125/PN16 flanged ports.

For 300 psig/PN25 flanges - Valve body shall be ductile iron with ANSI-250/PN25 flanged ports.

The valve shall be selected and installed in accordance with the manufacturer's instructions and be suitable for the pressure and temperature specified.

## Insulation

### (Available for 2.5" - 6"/65-150 Flo-Trex Valves)

Each valve shall be furnished with a pre-formed removable PVC insulation jacket to meet ASTM D1784 Class 14253-C, MEA #7-87, ASTM-E-84 and ASTM136 with a flame spread rating of 25 or less and a smoke development rating of 50 or less. There will be provided sufficient mineral fiberglass insulation to meet ASHRAE 90.1-1989 specifications in operating conditions with maximum fluid design operating temperature range of 141°F-200°F (60°C-93°C) and mean rating temperature of 125°F (52°C).

EXPERIENCE BUILDING...

**S. A. Armstrong Limited**  
23 Bertrand Avenue  
Toronto, Ontario  
Canada, M1L 2P3  
T: (416) 755-2291  
F (Main): (416) 759-9101

**Armstrong Pumps Inc.**  
93 East Avenue  
North Tonawanda, New York  
U.S.A., 14120-6594  
T: (716) 693-8813  
F: (716) 693-8970

**Armstrong Holden Brooke Pullen**  
Wenlock Way  
Manchester  
United Kingdom, M12 5JL  
T: +44 (0) 161 223 2223  
F: +44 (0) 161 220 9660



© S.A. Armstrong Limited 2009

For Armstrong locations worldwide, please visit [www.armstrongpumps.com](http://www.armstrongpumps.com)