

ARMSTRONG

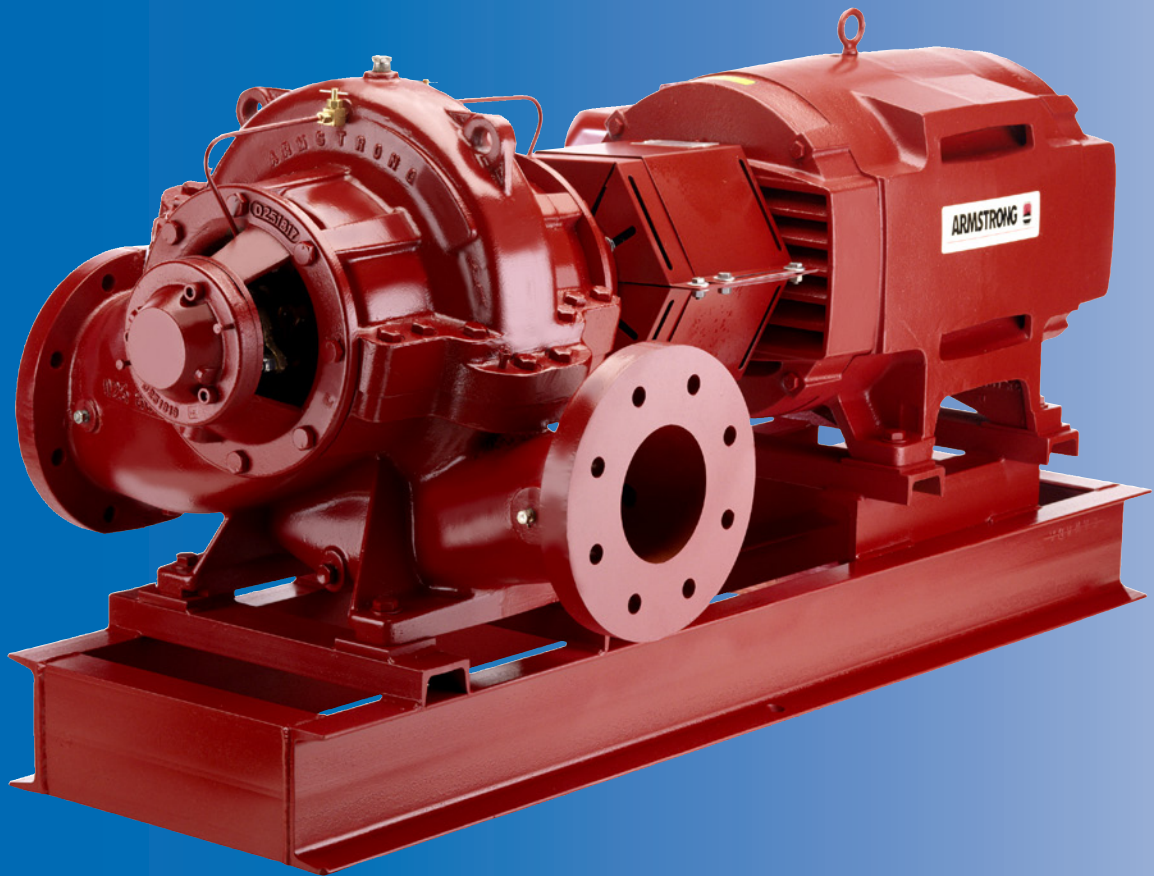

Horizontal Split Case Pump

FILE NO:	46.10
DATE:	Jan. 21, 2010
SUPERSEDES:	46.10
DATE:	Nov. 12, 2007

Armstrong takes you back to the future with the Series 4600 Horizontal Split Case (HSC) Pump for HVAC and industrial applications.

The Series 4600, drawing on over 100 years of pump design expertise and leadership, is the state of the art in HSC pumps. It meets or exceeds the requirements of its intended market applications.

This Family of pumps capitalize on the “Tilted Parting” concept to minimize turbulence at the eye of the impeller by its straight laminar approach, thus maximizing efficiency. This also results in the lowest profile and minimum floor space of any HSC pump on the market today. The family was designed with commonality of parts, low installation costs, and ease of maintenance objectives.

1 Recirculation

- ▶ External seal/packing recirculation lines
- ▶ Abrasives separation available as an option

2 Shaft Sealing with Mechanical Seal

- ▶ Unique cartridge design with standard mechanical seal
- ▶ Replaceable by removing bearing housing
- ▶ Wetted parts not disturbed
- ▶ Packed glands available

3 Coupling

- ▶ Flexible coupling
- ▶ Optional 3½” spacer coupling available allowing mechanical seal replacement without disturbing motor

4 Leakage Containment

- ▶ Fitted with drain connection

5 Stuffing Box Housing

- ▶ Self-contained combination bearing & seal housing

6 Casing Wear Ring

- ▶ Replaceable case wear rings
- ▶ Ease of maintenance
- ▶ Impeller wear ring available as an option

7 Impeller

- ▶ Hydraulically balanced double suction
- ▶ Dynamically balanced
- ▶ Minimum axial thrust
- ▶ High efficiency throughout operating range

8 Bearings

- ▶ Easy removal with bearing nut
- ▶ Permanently sealed grease lubricated bearings for extended life
- ▶ Low friction lost bearing
- ▶ Maintenance free

9 Bearing Housing

- ▶ Easy bearing replacement without removing top casing

10 Shaft

- ▶ Minimum deflection for long bearing and seal life
- ▶ Minimum vibrations
- ▶ Identical shaft and parts for left and right hand drives

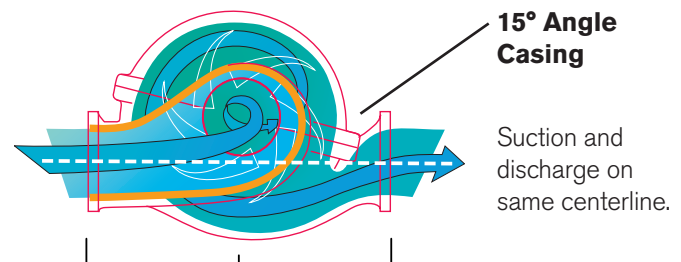
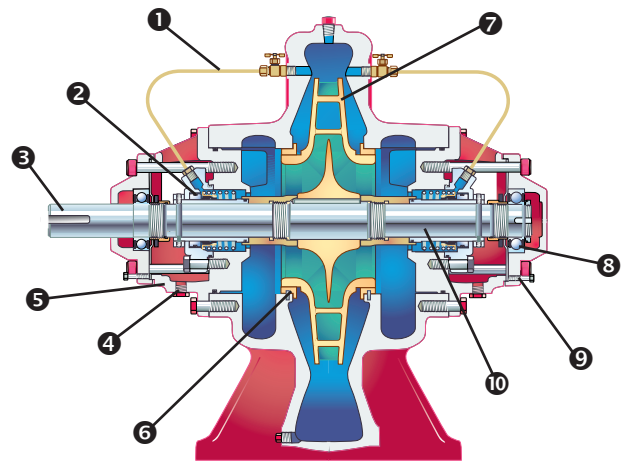

Tilted Parting Design Casing

- ▶ Permits laminar approach to eye of impeller
- ▶ Lower NPSH required
- ▶ Lower pump profile
- ▶ Minimum pump footprint
- ▶ Removeable rotating element without disturbing piping
- ▶ Low foot-mounted casing to reduce vibrations

Series 4600 - Horizontal Split Case

► Special Features

Cartridge Mechanical Seal

► Cartridge Style Mechanical Seal

Mechanical seal and seal plate are mounted on the shaft sleeve, as a single cartridge-style assembly.

► Service With Ease

The one piece cartridge assembly is easily removed for service. The replacement assembly may be installed, just as easily, with no special seal adjustments necessary. Standard mechanical seal is an industry standard design and readily available at local seal supply houses.

► Greater Temperature and Pressure Parameters

Various types of mechanical seals and packed glands are available to extend the standard pressure and temperature parameters.

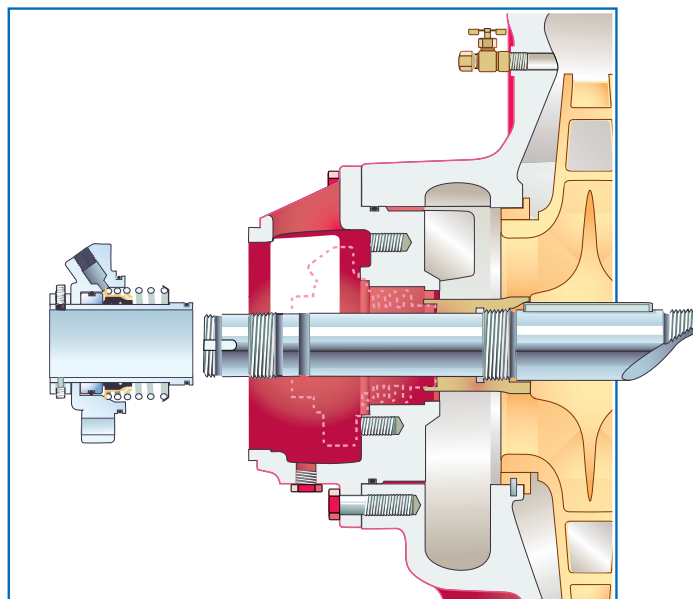

Service of Bearings

► Bearings Removed Without Disturbing Top Cover

Remove the bearing cover to expose the bearing for service.

► Service With Ease

All bearings contain a removal nut on the impeller side of the bearing. Bearing removal is easy. Simply lock the shaft and rotate the removal nut until the bearing is free.

► No Special Tools or Adjustments Necessary

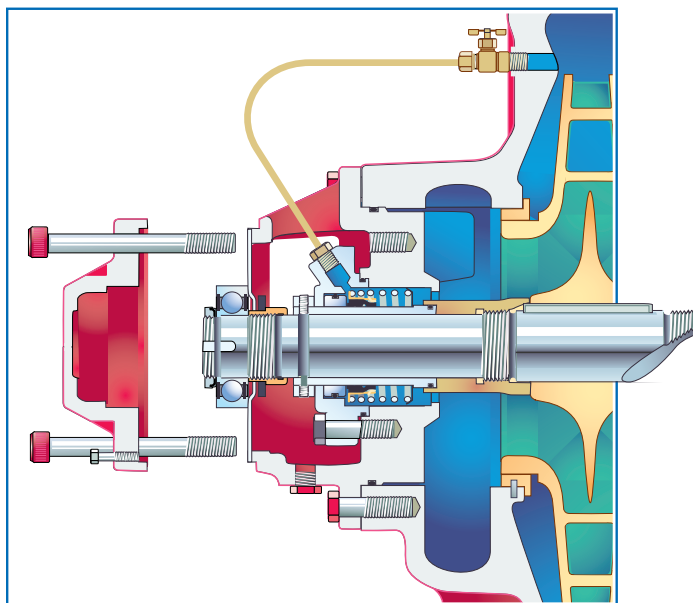

Materials of Construction	
Parts	Standard Material
Casing	Cast iron - class 30
Impeller	Bronze - alloy 844
Wear Ring	Bronze - alloy 936
Shaft	Carbon steel - C1045
Shaft Sleeve	Stainlesssteel - 304
Mechanical Seal	Silicone carbide/carbon Stainless steel - 304
Bearings	Grease lubricated

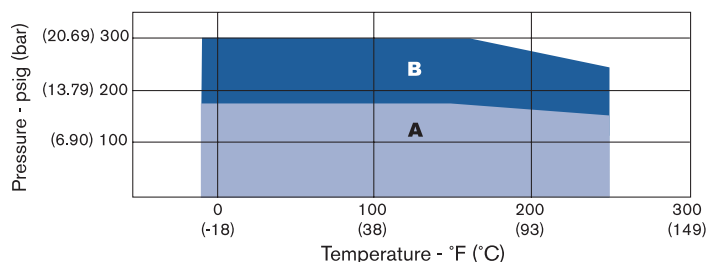

Legend: **A** Cast Iron Casing - ANSI 125# flanges
B Cast Iron Casing - ANSI 250# flanges

Contact factory with higher temperature or pressure requirements.

► Typical Specifications

1.0 Pumps – Horizontal Split Case, Centrifugal

Provide Armstrong Horizontal Split Case pumps, single stage, double suction type, with pump characteristics which provide rising heads to shut off.

Refer to pump schedules for pump flows, heads, motor speed, enclosure, efficiency and power requirements.

Pumps shall be Armstrong Series 4600 Horizontal Split Case type, each with flexible type coupling and OSHA guard and mounted, with motor, on a fabricated steel baseplate.

2.0 Pump Construction

2.1 Pump Casing

Cast iron, axially split, with 15° angle tilted parting to allow for lower NPSH requirements and to minimize pump dimensions.

Suction and discharge connections, located in the lower casing, shall be flanged and of sizes indicated in the schedule and shall be drilled and tapped for gauge connections.

Suction and discharge connections shall be on the same elevation.

The top of the casing and the rotating assembly shall be removable without disturbing the piping connections.

2.2 Wearing Rings

The pump casing shall be fitted with replaceable bronze wearing rings.

2.3 Impeller

Bronze, double suction, fully enclosed type. Dynamically balanced.

2.4 Shaft

Carbon steel, designed for minimum deflection and vibration.

2.5 Shaft Sleeves

Shall be stainless steel and form components of the cartridge mechanical seals.

2.6 Mechanical Seals

Each seal chamber shall be fitted with a cartridge type mechanical seal.

The seal component shall be of stainless steel construction with carbon vs silicone carbide faces and EPDM secondary seal.

The mechanical seal, shaft sleeve and seal plate shall be easily removable as a single component.

Provide seal plates with factory installed flush lines.*

2.7 Bearings

Supply dust tight deep groove ball bearings. With permanently sealed grease type lubrication.

Bearings shall be mounted in cartridge type housings, that are replaceable without opening the pump casing.

Bearings shall be removable by simply rotating the removal nut behind the bearing. No special tools or pullers are to be necessary.

3.0 Motor

Motor Horsepower ratings shown on the schedule are minimum acceptable and have been sized for continuous operation without exceeding full load nameplate rating over the entire pump curve, exclusive of motor service factor.

4.0 Mounting and Testing

Pumps shall be hydrostatically tested to 150% of the maximum pump working pressure.

The pump and motor shall be mounted and aligned at the pump manufacturer's factory on a common baseplate. Final alignment shall be made, on site, after the pump is installed and brought to operating temperature.

If supplied, the drip pan tapped connection shall be piped to the nearest drain.

*Seal flush line fittings, if required:

Supply in each flush line to the cartridge mechanical seal a 50 micron cartridge filter and sight flow indicator, to suit the working pressure encountered.

Filters shall be changed, by the installing contractor, after system flushing and on a regular basis until turned over to the owner.

Alternately for pumps with differential pressures exceeding 30 psig (2 bars):

In each flush line to the cartridge mechanical seal, supply a cyclone type separator with sight flow indicator.

EXPERIENCE BUILDING...

S. A. Armstrong Limited
23 Bertrand Avenue
Toronto, Ontario
Canada, M1L 2P3
T: 416-755-2291
F: 416-759-9101

Armstrong Pumps Inc.
93 East Avenue
North Tonawanda, New York
U.S.A., 14120-6594
T: 716-693-8813
F: 716-693-8970

Armstrong Holden Brooke Pullen
Wenlock Way
Manchester
United Kingdom, M12 5JL
T: +44 (0) 161 223 2223
F: +44 (0) 161 220 9660



© S. A. Armstrong Limited 2010

For Armstrong locations worldwide, please visit www.armstrongintegrated.com