

Conversion from Constant Flow System To Variable Flow

HOW TO SAVE PUMPING ENERGY IN HYDRONIC HVAC SYSTEMS

Hydronic HVAC equipment is typically oversized; even for design day conditions. Design day conditions are the design flow and head losses necessary to meet system heat loss calculations based on the listed highest design and lowest temperature periods for the geography. Many times equipment is oversized by design to lessen the risk of an equipment redesign being necessary due to system calculation errors and/or building changes during construction.

As the calculated design day condition in most parts of the world is rarely met, a great deal of energy is wasted by over-pumping and/or throttling to optimize the installed equipment. Most installed hydronic HVAC systems are constant flow systems using constant speed pumps and as the system load varies with the outdoor temperature and building use the excess conditioned water in the HVAC hydronic system is shunted past the loads through bypass lines and returns unused to the source. In such systems the potential for energy savings and reductions in electricity bills is high and this paper discusses ways to quite easily achieve those goals.

CONSTANT FLOW SYSTEM TO VARIABLE FLOW SYSTEM

To reduce power costs, it may be decided to change the system from a Constant Flow type to Variable Flow. With 3-way valves installed there is no opportunity to reduce the pump flow, as the valve bypass port is design to open as the load is reduced; resulting in constant pump flow. Should the bypass line valve be closed, the 3-way valves would effectively become a 2-way valves. As the valve then modulates closed to reduce a load coil flow on mild days, the excess flow would no longer be bypassed; thus the loop differential head would increase as the control valve throttles the flow. As this throttling reduces the system flow, pumping power needs are reduced.

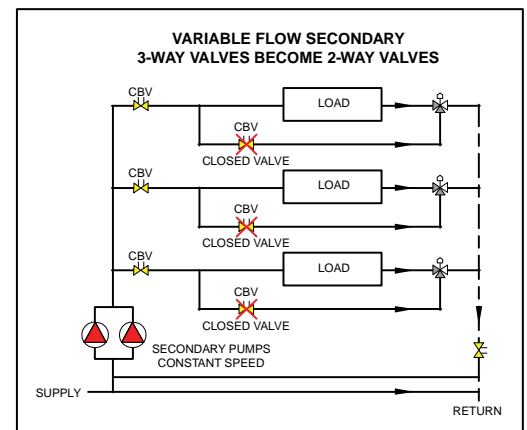

THE VALUE OF VARIABLE SPEED PUMPS IN VARIABLE FLOW SYSTEMS

There are two major decisions to be made to derive full benefits from variable flow systems. The first is whether to make the system design suitable for variable flow and the second is to understand the value of investing in variable speed pumps. Converting the system to variable flow alone while retaining constant speed pumps will save pumping energy; typically 20% to 30%. This energy saving does not come easily however. As the flow from constant speed pumps is throttles by 2-way valves the pressure across the pumps and the control valves increases. This leads to some reduction in the pump life due to higher bearing loads and, perhaps more importantly, makes the conditioned spaces temperature harder to maintain. As the pressure across control valves increases the valves must close to a greater extent to allow a given amount of water to pass through the load. With higher differential pressures a small change in the valve lift results in a large change in the flow; this can cause 'hunting' of the valve stem position resulting in loss of effective control with fluctuating conditioned space temperatures.

Variable speed pumps, combined with a control system that recognizes current system conditions, will reduce pump speed during part-load periods, reducing pressure in the system to a value that satisfies the current load flow requirements with minimum over-pumping. This will reduce pumping energy use to a minimum, extends the life of the pumps and motors and increase the effectiveness of the control valves by reducing the differential pressure across them.

BENEFITS FROM CONVERTING CONSTANT FLOW SYSTEMS TO VARIABLE FLOW WITH VARIABLE SPEED PUMPS

- Reductions in absorbed pumping power that are realised when a heating or cooling system runs under 2-way control with variable speed pumps

- Reduction in total operating costs, which can often payback the change costs expended in the first year. If the payback is in the first year, then no new capital is required and the conversion costs can be expended out of the revenue budget
- Armstrong have published an easy to use Opportunity Calculator for easy return on investment calculations which is used to demonstrate to the user/operator in a transparent way the cost savings and payback time for the new equipment
- Reduced water borne noise, as water velocity is reduced
- Longer product life, as it is no longer operating at full speed
- No check valve chatter, as the pumps work on soft start and soft stop under the variable speed control
- In the UK a newly converted system may help the building qualify for a higher grade Energy Performance Certificate. If the modified building is run through the SBEM energy model software, a reduced input power will be evident
- In North America a newly converted system will help the building achieve a desired LEED certification

BENEFITS OF VARIABLE SPEED PUMPS WITH SENSORLESS CONTROL

Armstrong is able to supply a unique Sensorless control, for duty standby systems, integrated within Vertical In-Line pumps, where the pumping unit will react to the needs of the system without the resources required to acquire, install and wire a remotely mounted system feedback sensor. The pump curve data is mapped into the control software which can precisely place the operating position on the pump curve by monitoring the motor power and speed. This enables the unit to react to system condition in precisely the same manner as conventional controls react to a remotely mounted system feedback sensor.

VARIABLE FLOW SYSTEM CONVERSION – PIPING CONSIDERATIONS

A challenge for many hydronic system designers is to correct a misunderstanding by some building owners/operators that a system can be converted to variable speed with all its implied energy and cost savings merely by installing an adjustable frequency drive onto the pump motor.

In reality the system piping inside and/or outside of the Plant Room may require modifications. In the following sections 3-way and thermostatic radiator valves are discussed in addition to compensated heating systems with mixing valves, fan coil unit systems and primary pumps. The need for a bypass line on 2-Way valve control systems is also discussed.

VARIABLE FLOW SYSTEM CONVERSION – RADIATOR SYSTEMS

Radiator heating systems are easily converted to variable flow systems. Many radiators are already fitted with Thermostatic Radiator Valves. (TRV) If not, they can be readily and inexpensively installed. They do not require an electrical supply and can be easily set to provide effective room temperature control. TRVs interrupt the water flow when the room reaches design temperature. A self-regulating variable speed pump such as the Armstrong IVS Sensorless pump will recognise this reduction in water flow demand and reduce speed; saving power and energy costs.

VARIABLE FLOW SYSTEM CONVERSION - VALVE CONVERSION

3-way valves are the work-horses for heating and cooling control of conventional constant flow systems. Connected through the Building Automation System (BAS) to thermostats located in conditioned spaces, the 3-way motorised valve either directs the heating or cooling water through the coil in the Air Handling Unit (AHU), or, if the space being served is at normal operating temperature, the flow is directed through the bypass line to the return piping. The bypass line is normally fitted with a regulating valve, set so that the bypass pressure drop matches that of the coil in the AHU. Thus, whichever way the water is being directed, the pump sees little change in flow or head and continues to operate at full speed.

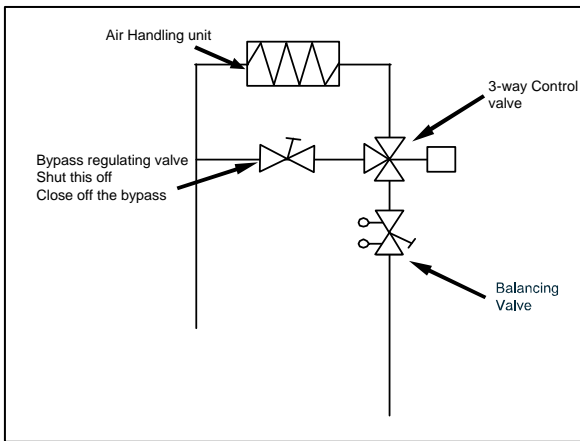

Current state of the art variable flow energy saving pumping systems use a 2-way motorised control valve and are installed without a bypass line.

To convert existing 3-way valve systems to 2-way valve configuration is relatively easy. Simply close the regulating valves in the bypass lines. With the bypass closed, when the 3-way valve modulates attempts to divert the flow around the load and through the bypass, it will restrict the flow rate instead. An Armstrong IVS Sensorless pump will sense this deviation from its control curve and reduce speed until the pre-set control curve, the system resistance curve and the pump performance curve at a new speed converge for the new operating point. Thus power is saved and operating costs reduced. Water velocity is reduced, noise is reduced and equipment time between repairs is extended.

This conversion can be applied to most AHUs as they are generally installed with these 3-way valves and have easily accessible bypass lines, fitted with regulating valves. It gets more challenging with systems feeding Fan Coil Units (FCU) as they are often supplied without motorized valves.

VARIABLE FLOW SYSTEM CONVERSION - FAN COIL UNITS

Fan Coil Units (FCUs) are almost smaller versions of AHUs. They are generally located in the conditioned space being served; typically in a ceiling or wall space. An FCU is served by pipes to feed chilled water and heating water and may have ductwork from the HVAC air system. Older FCUs are controlled by a room thermostat and control their output by a combination of a multispeed fan and/or a damper which throttles the air flow into the space being served.

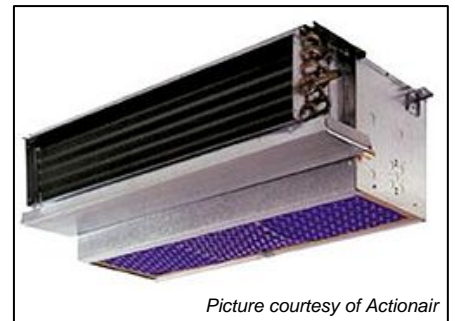

Picture courtesy of Actionair

Modern fan coil units may be fitted with 4-way control valves, either the rotary type, or the vertical acting type shown in the picture. Both provide an internal bypass from the supply to the return line.

Converting these valves to 2-way is not simple and involves getting access to the FCU, of which there may be many, opening them up and changing out the valve.

This expense will make the payback period very long. An alternative strategy to convert to variable flow systems is required.

Variable flow system conversion - Control of return temperature for FCUs

One alternative strategy is to leave the FCU and controls in place unchanged and investigate an alternate control opportunity. When the FCU is operating on bypass, the water leaves the FCU at the same temperature that it enters, no heat is being supplied into or taken from the conditioned space as the temperature setting has been reached. This means that pumps can be controlled by measuring the return temperature and can reduce the flow rate/operating speed until the return temperature is back to design return temperature range. To prevent the possibility that certain zones may be underpumped when others zones are satisfied, multiple sensors need be applied to return pipework around the building so that all areas are served. Currently the Armstrong IPS system would serve for pump control for up to 18-zones. Armstrong is further developing a controls package for this application.

VARIABLE FLOW SYSTEM CONVERSION – PRIMARY PUMPS

Primary pumps typically operate at constant speed to produce a constant flow of water through the chiller or boiler and serve a low loss recirculation header. The secondary pumps take water from this low loss header to circulate through heating or cooling building load heat exchangers. As boilers and chillers need minimum flow requirements; secondary pumps have the highest opportunity for energy savings.

On the other hand, many primary pumps are over-sized for the low resistance of the system they serve. As a result many are throttled back, which wastes power and money. One solution is to fit a drive to the motor, open up the throttling valve and manually reduce the pump speed until design flow rate is achieved. No automatic controls are required. Speed is reduced and energy is saved for the life of the system. Noise will be reduced if the throttle valve were noisy. Many modern chillers can accept a variable flow through their heat exchangers. Request minimum flow data from the chiller or boiler manufacturer and any controls advice before proceeding with any changes to primary pumps. Armstrong can supply IVS Sensorless rotating assemblies for existing Armstrong VIL pumps, which will make primary pump energy savings a real possibility with little capital cost.

VARIABLE FLOW SYSTEM CONVERSION - THE BYPASS

Variable flow HVAC systems converted from 3-way control to 2-way valve control will find certain challenges when all of the 2-way valves are shut off:

- 1) The pump may overheat when it continues to run against a closed valve at its minimum speed. This may lead to premature seal failure or thermal shock cracking issues if cold water is suddenly allowed into a hot cast iron casing
- 2) The temperature of the conditioned water in the headers and remote risers, now stationary, will decay to ambient. This means that when a space eventually requires heating or cooling, there will be a delay as the freshly heated or cooled water from the boiler or chiller finds its way from the plant room, up the riser and along the floor to the terminal. This may cause user discomfort, generating complaints
- 3) One solution for 2-way motorised valve control systems is to fit a remotely mounted bypass line with a control valve. This, suitably engineered and controlled, will maintain a minimum flow rate in the header, keeping the system pipework at the correct temperature and prolonging pump and pump seal life
- 4) The bypass flow required is generally between 5 and 10% of a single pump design flow rate. However, as the pump will be operating at the lowest speed required to maintain the minimum system pressure, this flow should be calculated based on minimum speed Best Efficiency Point (BEP) from the variable speed pump curve
- 5) Several methods of providing a suitable bypass are discussed in the following sections:

VARIABLE FLOW SYSTEM CONVERSION - BYPASS CONTROL I

One easy method for bypass control that Armstrong recommends is that, when converting a 3-way valve system to 2-way configuration, simple leave the most remote 3-way valve bypass line open on each riser. If there are only few loads in the zone, close the most remote 3-way valve bypass regulating valve 50% so that energy is not wasted with too much conditioned water being returned unused to the chiller or boiler. In this manner, water will only be bypassed when the remote load is satisfied and, as the remote load is typically the least served in the system, this would probably be when all loads are satisfied and bypass flow is required.

Other bypass opportunities are discussed in the following sections:

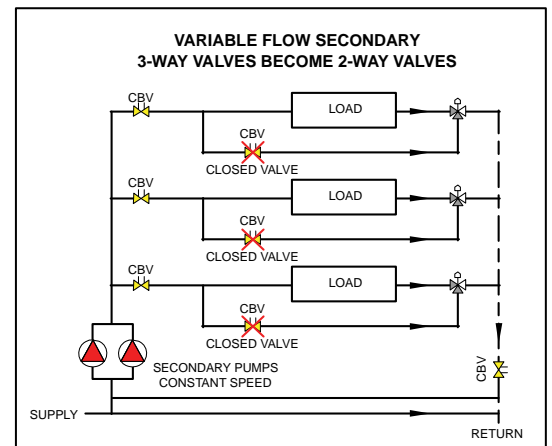

VARIABLE FLOW SYSTEM CONVERSION - BYPASS CONTROL II

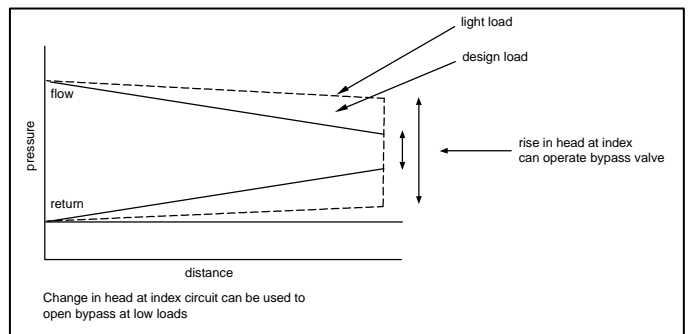
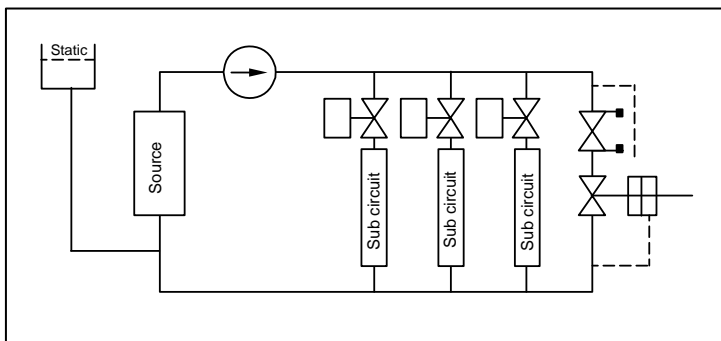

This example shows how a bypass valve is installed and controlled for variable speed pumps where the differential pressure controller is located at the pump. The pump in the picture is controlled to produce constant pressure local to the pump in the plant room. This design does not produce the largest value of energy savings, however it can explain the operation of the bypass easily. The diagram below the system schematic shows how the pressure varies around the system. The pressure is highest across the pump (on the left of the diagram) and then reduces as the water flow passes around the system supply piping. The pressure drops again through the index leg (On the right) and continues to fall as it returns to the pump through the return piping. When all the 2-way valves in the system are open, the water velocity is greatest and the friction / pressure losses are the greatest so that the differential pressure at the index leg is lowest. However, at low load, when all the 2-way valves are closed, the friction loss in the supply and return pipework is reduced, causing the differential pressure at the index leg to increase. This change in pressure can be used by a pressure controlled valve to open and allow water to pass through the bypass line, located at the end of the system. The understanding of where the differential pressure controller is located and the concept of friction loss reducing drastically in the distribution piping at low flows is fundamental in understanding Bypass Control sections II, III & IV.

VARIABLE FLOW SYSTEM CONVERSION - BYPASS CONTROL III

The installation illustrated has a differential pressure (DP) controller mounted on the index circuit for highest energy savings. The pressure will be constant at the remote point and will vary closer to the pump in the plant room as the loads vary and the pump speed adjusts to match the DP setting and the actual friction loss in the distribution piping. The pressure actuated bypass valve is located in the plant room. Normally closed, it senses the fall in differential pressure in a part load situation and opens, allowing a minimum flow through the pump. While simple and easy to install, it does not provide the minimum flow needed to keep the water in the distribution piping at the operating temperature.

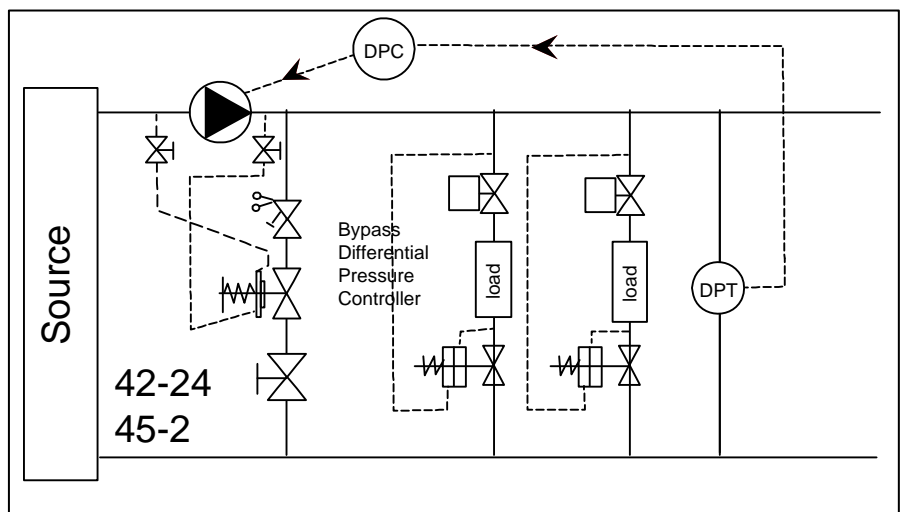

VARIABLE FLOW SYSTEM CONVERSION – BYPASS CONTROL IV

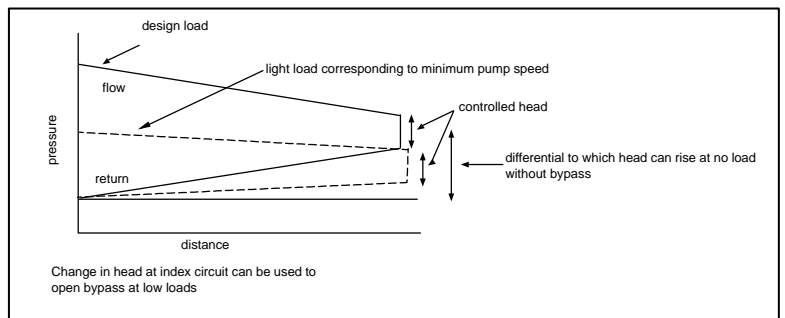
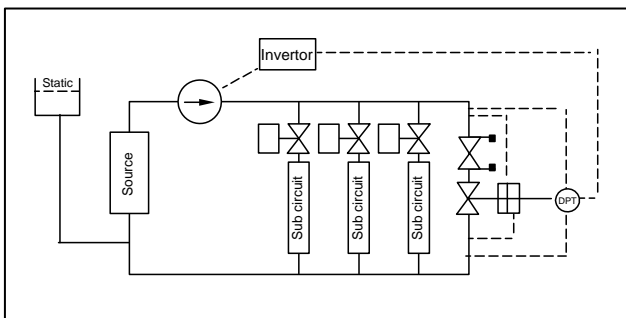

This bypass example provides a good bypass functionality; however the set up is more complicated. In this case both the bypass and the differential pressure transducer are mounted remote to the pump on the index line. This produces the best energy savings and the pipework maintains the required operating temperature.

For this to operate effectively the minimum frequency on the drive control must be set high enough that at low load, where the losses in the distribution piping are small as the flow rate is very low, the pump will operate at its minimum set speed and move left, up the performance curve, increasing the pressure at the index, causing the bypass valve to open. The closed valve pressure of the pump at its minimum frequency must be 25% higher (12% higher frequency) than the control pressure setting of the pressure transducer at the index.

VARIABLE FLOW SYSTEM CONVERSION - BYPASS CONTROL IV – PUMP OPERATION

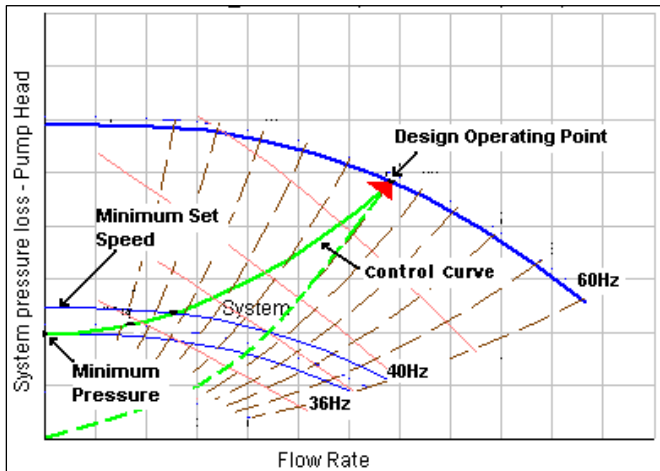

The above diagram illustrates how the pump performance tracks the load on the system, when set up to open a bypass valve mounted on the index. Beginning at the design operating point, the pump will track the quadratic control curve down to the minimum speed setting. As the system 2-way motorised control valves continue to close, reducing the system flow, the controls will not allow the drive to reduce speed further so the operating point must move to the left along the minimum set speed performance curve, causing a rise in pressure as it approaches zero flow rate. This rise in pressure actuates the bypass valve, which will open, permitting the minimum flow to pass through the bypass line.

VARIABLE FLOW SYSTEM CONVERSION - PUMP TOPICS

If the existing motors are going to be re-used and will be fitted with drives for the first time, checking the suitability of the motor for inverter use with the manufacturer's representative in your area. High voltage spikes from adjustable frequency drives apply more stress to the insulation systems of motors than constant speed application. Motor insulation not suitable for inverter use may break down, causing motor failure. Generally, older motors with Class B insulation may not be suitable for inverter use and modern motors with Class F insulation should be checked also.

Generally the motor manufacturer will need to know the drive carrier frequency setting and the cable length between the drive and motor. If in doubt, it makes sense to change out the motor if supplying a new drive. If the pumping unit is an Armstrong vertical in-line type, a new complete rotating assembly, supplied with Sensorless Controls can probably be supplied to fit directly into the existing pump casing. Ask your local Armstrong representative for more information.

VARIABLE FLOW SYSTEM CONVERSION - ELECTRICAL TOPICS

In a plant room, the conversion work involves fitting the new rotating assemblies to the existing pump bodies or supplying stand-alone controls, Sensorless or not, for existing pumps. The existing pump control panels and the contactors inside them are now redundant and may now be removed from site. If the owner prefers to retain the existing control panel as is contains other equipment and is already set up for BAS interface, the power cables can be wired into the new drives instead of the old motors. Trying to fit the drives inside a central panel with long cable to the motors is not the best solution. This can lead to harmonics problems causing noise and motor insulation damage and is to be avoided. Decentralized controls are common today and Armstrong can supply integrated controls on Vertical Inline pumps up to 75hp (55kW)

VARIABLE FLOW SYSTEM CONVERSION - CONTROLS TOPICS

Once the mechanical and electrical installation is complete, the controls company can if necessary or desired connect the controls to the BAS / BMS. They can monitor the drive status and deliver an enable or disable signal. Armstrong drives are compatible as standard or with optional cards to all the usual communications protocols; such as Lonworks, BACnet, Modbus, Metasys N2 or Apogee FLN.

VARIABLE FLOW SYSTEM CONVERSION - SUMMARY

- The VARIABLE FLOW SYSTEM conversion saves money
- The heating / cooling system works better
- Building regulation compliance is enhanced
- Pumps and drives are easily installed - often with no change to pipework

- Control valve changes are easy to do – often closing the bypass line to convert 3 way valve systems to 2 way systems is best done by the building maintenance staff who are familiar with their location.
- The plant room is cleaned up with fewer control panels

SENSORLESS PUMP TECHNOLOGY

Issues relating to sensors:

- For best energy savings the sensor needs to be installed remotely
- Mechanical and electrical installation costs incurred
- Exact position for sensor in system is often difficult to determine
 - If installed remotely loads closer to the pump may be under-pumped when needing flow and remote loads are satisfied
 - Bringing the sensor closer to the pump is expensive and prevents highest energy savings
- Sensors are prone to failure and are regularly damaged or installed incorrectly

Placing the DP sensor remotely facilitates greater turndown and hence greater energy savings although some capital and installation costs will be incurred by installing the sensor at a location distant from the pump and controls. To save on direct cable runs back to the drive it is possible to put the signal through the BAS / BMS and bring it back out in the plant room; however cost for extra BAS / BMS points will still be incurred. If the sensor is placed across the most remote load leg and remote loads are satisfied and loads closer to the pump need full flow, the pump speed and back pressure in the piping may not be sufficient to supply full flow to the closer loads; resulting in under-pumping. BSRIA in the UK and others recommend that the sensor be placed 2/3rd the way down the system as a trade off between energy savings and satisfactory system operation. Sensors are electro mechanical devices and can fail in the system. If you read **Benefits of variable speed pumps with Sensorless Control** on above you may now know that Sensorless Control can do everything a remote sensor can do, without the cost of supplying, installing and wiring the sensor. Ask your local Armstrong representative for more details.

VARIABLE FLOW CONVERSION – IVS OPPORTUNITY CALCULATOR

The calculator is on-line at: <http://www.armstrongpumps.com/ivs/Calculator.html>

The Opportunity Calculator helps the user estimate the potential energy savings in the system and how long the payback period will be. A system lifetime cost savings estimate is also detailed. Simply complete the data input on the first screen; including system flow rate, head losses, operational hours per year, pump efficiency and local electricity cost. The cost of the Sensorless pumping unit is entered later on the 'IVS pump cost' screen. This cost would be the incremental cost of the sensorless unit over a constant speed pump for a new system (Constant pump cost entered on the appropriate screen) or the full cost of the sensorless unit if the unit is to pay for itself solely from energy savings (Use constant speed pump cost of zero). The minimum system pressure defaults to 40% of the design pump head and the part-load flow defaults to the ASHRAE 90.1 part load benchmark of 50% of design flow. Each screen takes you step by step through the constant speed continuous power usage and the variable speed power usage under normal part load conditions. Later screens compare the two running costs and calculate the payback.

This calculator is quite conservative and estimates the payback from energy savings only. Sensor costs are not included which could easily remove \$2,000 (£1200) from the investment total.

These are exciting times with energy saving fruits low-hanging in many hydronic HVAC systems just waiting to be picked. Your local Armstrong representative will be pleased to help you understand the true value of variable speed HVAC pumping and how it can easily reduce your energy costs and pay for the conversion quickly from your own savings.